

IMPACT 500 series

On-ear Bluetooth® headset with ANC

User Guide

DSBT7 | DSBT4

Contents

Welcome	3
Package contents	4
IMPACT 500 at a glance.....	5
Icons at a glance	5
Headset at a glance.....	5
Dongle at a glance.....	12
Getting started	13
Connection possibilities	13
A Connecting the dongle.....	14
B Pairing with your Bluetooth® devices.....	15
C Connecting via USB & charge the battery.....	19
Installing the EPOS Connect mobile app.....	20
Installing the EPOS Connect desktop app.....	20
Changing audio settings – Microsoft® Windows	21
How to wear the headset.....	22
Adjusting and wearing the headset	22
Positioning the microphone.....	22
How to use – the basics.....	23
Switching the headset on - auto connect.....	23
Switching the headset off	24
Changing the volume.....	25
Muting the headset's microphone.....	27
Using Active Noise Cancellation.....	28
Using TalkThrough.....	29
Making calls using the headset	30
Making a call.....	30
Accepting / rejecting a call	31
Putting a call on hold (pause).....	33
Ending a call.....	33
Managing multiple calls.....	34
Using the voice assistant / voice dial.....	35

Using Microsoft® Teams	36
Invoking Microsoft® Teams	36
Checking Teams Notifications	37
Raising hand in a Teams meeting.....	37
Listening to media	38
Good to know.....	39
Charging the headset.....	39
Verifying battery power / remaining talk time	41
Adjusting the Sidetone.....	42
Changing the voice prompts' language	42
Enabling / disabling voice prompts and tones.....	43
Changing settings for media mode	43
Enabling / disabling an Audio Limiter	44
Enabling / disabling Busylight LED.....	44
Enabling / disabling mute notifications	45
If you are close to leave the Bluetooth range.....	46
Pairing with the dongle	47
Maintaining & updating products.....	48
Cleaning the products.....	48
Transporting and storing the products	49
Replacing the ear pad(s)	50
Updating the firmware.....	51
Replacing the headset's rechargeable battery	54
If a problem occurs.....	55

Trademarks

The Bluetooth® word mark and logos are registered trademarks owned by Bluetooth SIG, Inc. and any use of such marks by DSEA A/S is under license.

USB Type-C® and USB-C® are trademarks of USB Implementers Forum.

All other trademarks are the property of their respective owners.

Welcome

Designed for modern communication, IMPACT 500 delivers clarity and comfort all day.

Certified for Microsoft Teams Open Office and over Native Bluetooth®, it connects directly to your device – no dongle needed.

EPOS industry-leading microphone technology blocks out background noise for clear, precise speech and focused conversations. Hybrid ANC and EPOS BrainAdapt™ reduce noise and listening fatigue in the open office, while an impressive 35 hours of talk time keeps you connected longer.

Key benefits & features

Industry-leading voice pick-up for focused conversations

EPOS' industry leading microphone technology powered by EPOS AI™ ensures your voice is crystal clear and professional every time.

Professional performance and a dongle free set-up

The IMPACT 500 is certified for Microsoft Teams over native Bluetooth and supports an optional dongle – making connectivity effortless.

Stay in control of your environment with hybrid ANC

Reduce background noise during calls or when you need to focus – helping you stay productive across diverse working environments.

All-day comfort engineered for calls and focused work

Breathable leatherette earpads and a super soft padded headband, maximizes comfort and eliminates pressure points, perfect for a busy workday.

Protect your brain in the open office

Boost focus and productivity with EPOS BrainAdapt™ technology, designed to protect your brain from fatigue caused by poor audio and noise.



For safety instructions, consult the Safety Guide.



For specifications, consult the Fact sheet available at [eposaudio.com](https://www.eposaudio.com)



A list of accessories can be found on the product page at [eposaudio.com](https://www.eposaudio.com)

Package contents

IMPACT 500 MS UC ANC WL

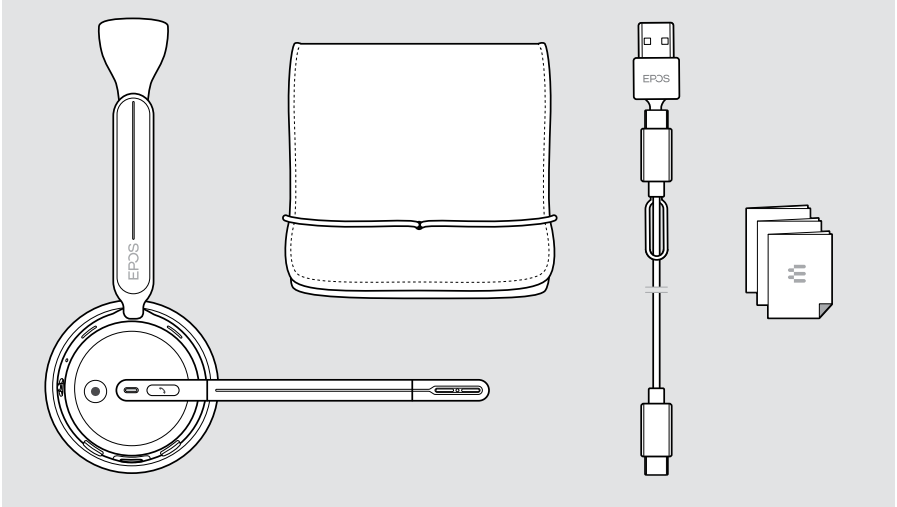



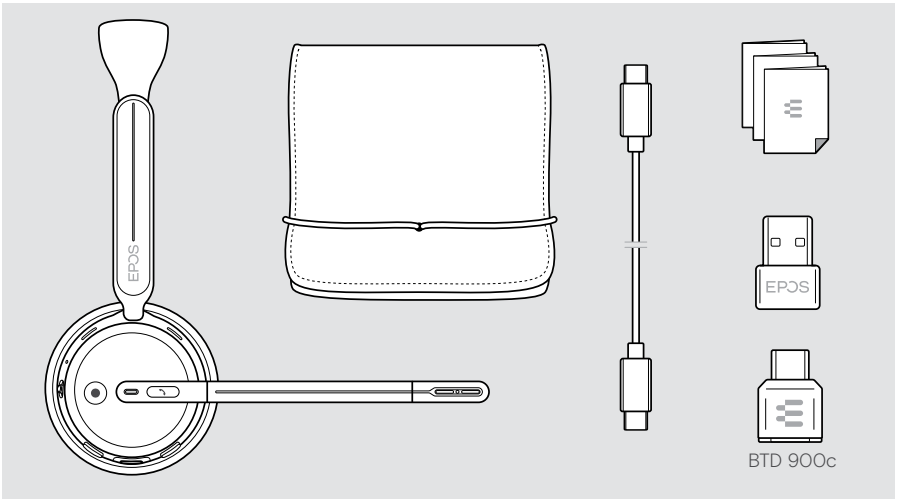



IMPACT 500 MS UC ANC WL USB-C+A



IMPACT 500 at a glance

Icons at a glance

	<p>Tap the button</p>		<p>Notes: Good to know</p>
	<p>Double tap the button</p>		<p>LED indications</p>
	<p>Press and hold the button</p>		<p>You hear a voice prompt or tone</p>

Headset at a glance

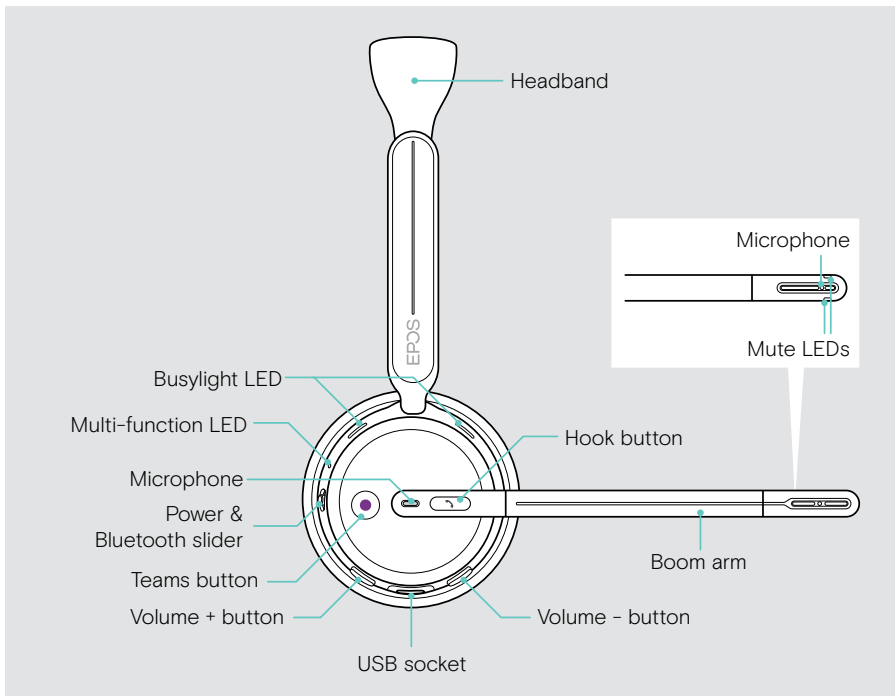

Headset 2nd earcup

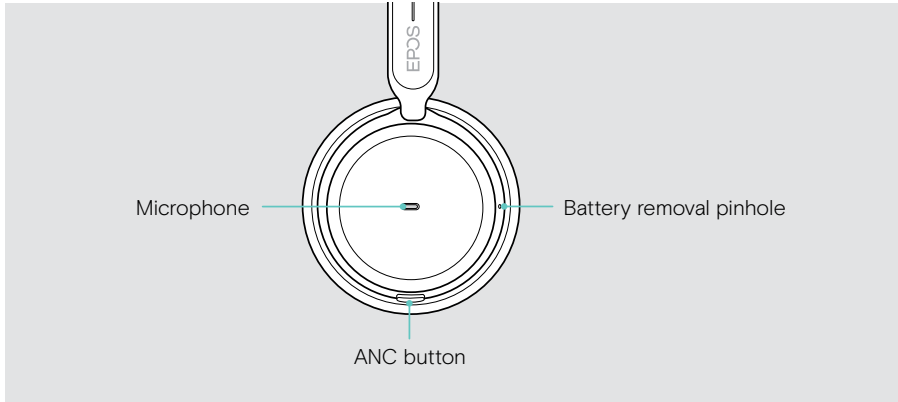

Headset LEDs at a glance







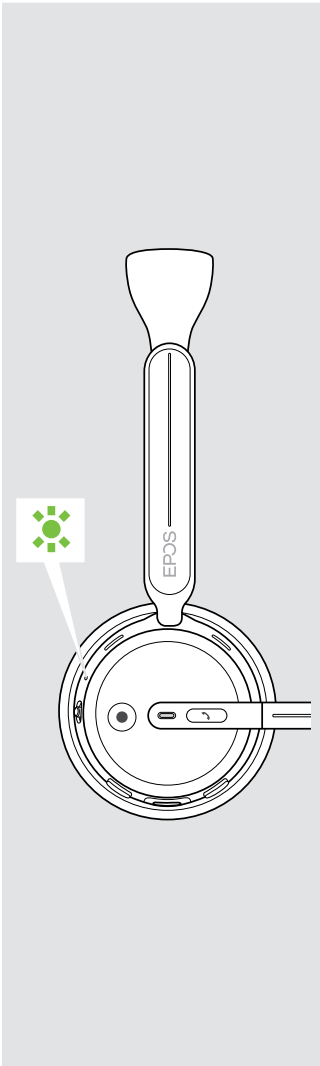





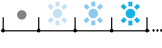



You can change some of the LED settings via [EPOS Connect](#).

Multi-function LED

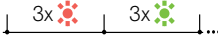

Meaning

3x 	Headset switches on
	Headset in pairing mode: searching for mobile device/dongle
	Headset searches for Bluetooth devices
3x 	Pairing was successful Connecting to Bluetooth device was successful
3x 	Headset switches off
  	Headset is being charged: color indicates battery status
  	Remaining battery power requested
	Headset fully charged
	Firmware is being updated
3x 	Pairing list has been cleared
	Headset resets to factory settings

Busylight LED

Meaning

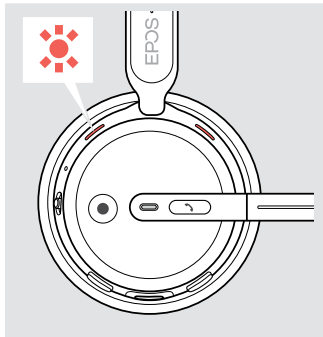

Incoming call:
if you do not wear the headset



Active call

Call on hold

Mute LED at boom arm

Meaning

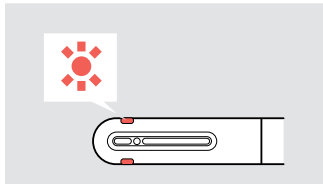

Microphone muted

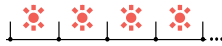

Talking while microphone is muted

Boom arm functions at a glance

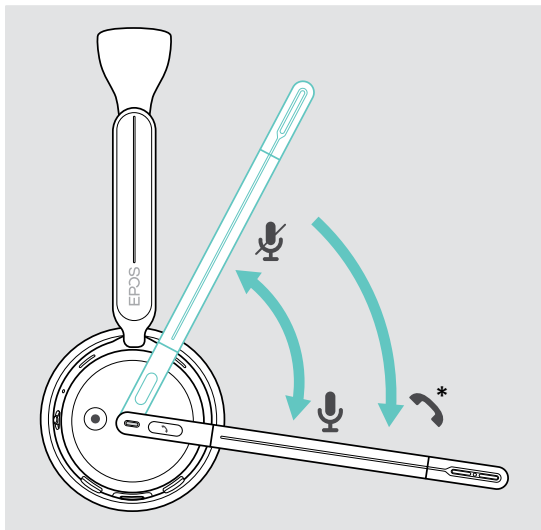

Lift boom arm:







- Mutes the microphone



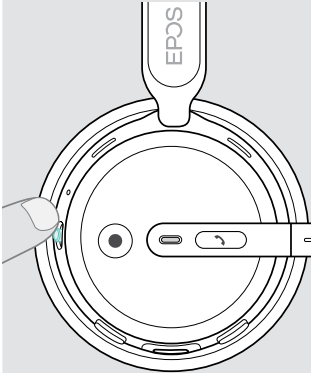

Lower boom arm:





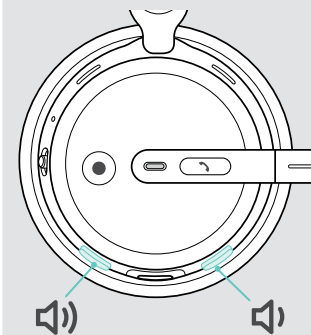





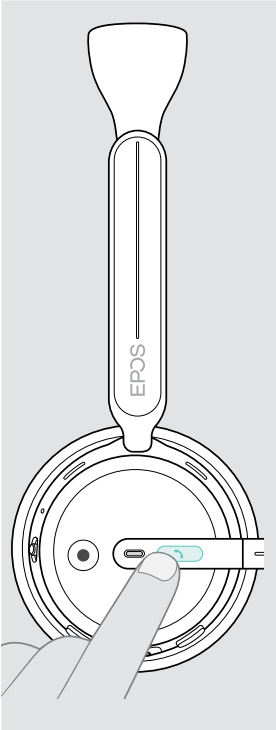

- Unmutes the microphone
- Accepts an incoming call



*This function can be activated/deactivated via EPOS Connect.



Headset buttons at a glance

Power & Bluetooth slider	Press	Function	Page
		Switches the headset on	23
		Switches the headset off	24
		Pairs the headset with a Bluetooth device	15
		Requests remaining battery power	41
		Cancels pairing (Pairing mode)	15
		Clears pairing list	57

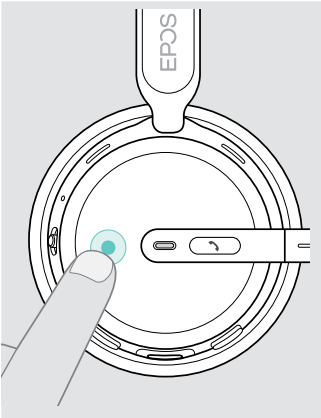
Volume buttons	Press	Function	Page
		Increases or decreases the volume (press or press and hold)	25
		Skips to the next track	38
		Skips to the previous track	38

Hook button	Press	Function	Page
		 Accepts a call	31
		 Ends a call	33
		 2 calls: Answers incoming & ends active call	34
		 2 calls: Ends active and keeps 2nd call on hold	35
		 Starts / pauses audio playback	38
		Cancels voice assistant	35
		 Puts an active call on hold (pause) / unholds call	31
	 2 calls: Answers incoming & puts active call on hold	34	
	 2 calls: Toggles between two calls	35	
		 Rejects a call	32
	Activates voice assistant	35	

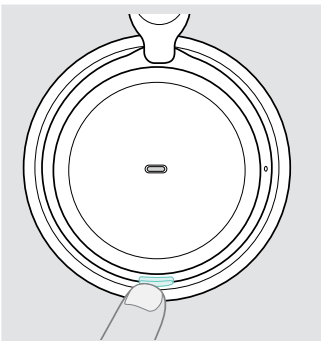
Teams button	Press	Function	Page
		<p data-bbox="580 260 841 287">Invokes Microsoft Teams</p>	<p data-bbox="938 260 972 287">36</p>
		<p data-bbox="580 459 885 512">Raises / lowers hand in a Teams meeting upon release</p>	<p data-bbox="938 470 972 497">37</p>

ANC button	Press	Function	Page
		<p data-bbox="580 735 818 762">Switches ANC on / off</p>	<p data-bbox="938 735 972 762">28</p>
		<p data-bbox="580 895 882 948">Switches TalkThrough on/off (only if ANC is switched on)</p>	<p data-bbox="938 908 972 935">29</p>

Dongle at a glance

The dongle BT-D 900c is included in the IMPACT 500 MS UC ANC WL USB-C+A bundle. It is also available as an accessory.

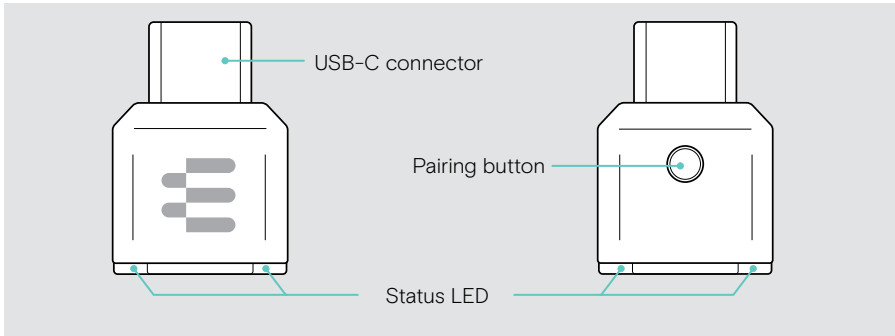

Dongle LEDs at a glance

Dongle	LED	Meaning
		Dongle tries to connect to the headset
		Dongle and headset connected Audio streaming
		Incoming call
		Active call
		Connected to Teams
		Teams notification
		Microphone of the connected headset is muted
		Dongle in pairing mode: searching for headset
		Pairing successful
		Pairing failed
		Clears pairing list

Getting started

Connection possibilities

You can connect the headset:

- **A** via the **Bluetooth dongle** to a computer **or**
- **B** via **Bluetooth** to a mobile device (e. g. smartphone, tablet) **or** via **native Bluetooth** to a Windows 11 PC (Microsoft Teams certified; no dongle required)
- **C** via the **USB cable** to a computer

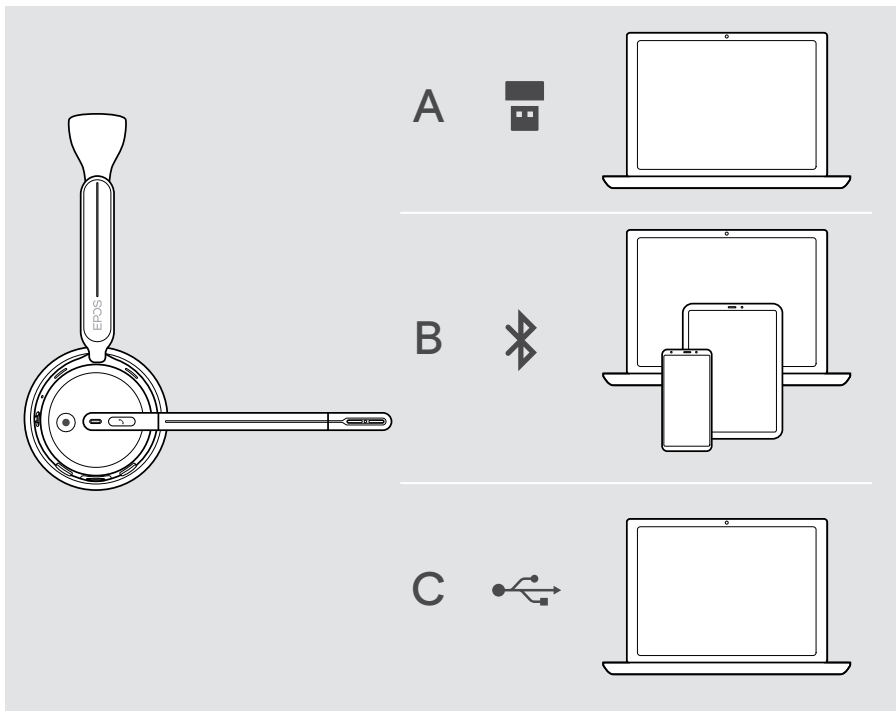

C If you connect the headset via USB cable it will automatically be charged. With the cable connected, you can use the headset even if the battery is empty.

A Connecting the dongle

The dongle BT-D 900c is included in the IMPACT 500 MS UC ANC WL USB-C+A bundle. Upon arrival the dongle is already paired with the headset. It is also available as an accessory: Follow the instructions on page 47.

- 1 Attach or detach the BT-D C to A Adapter.
Plug the dongle into a **USB-C or USB-A** port of your computer.
The dongle LED flashes blue while searching.
- 2 Move the Power slider to the center to switch on the headset.
The LED flashes 3 times green and 3 times blue as soon as it is connected to the dongle. The dongle LED flashes blue while searching for the headset and switches to white as soon as they are connected. If Microsoft Teams is running: The dongle lights up purple instead of white.

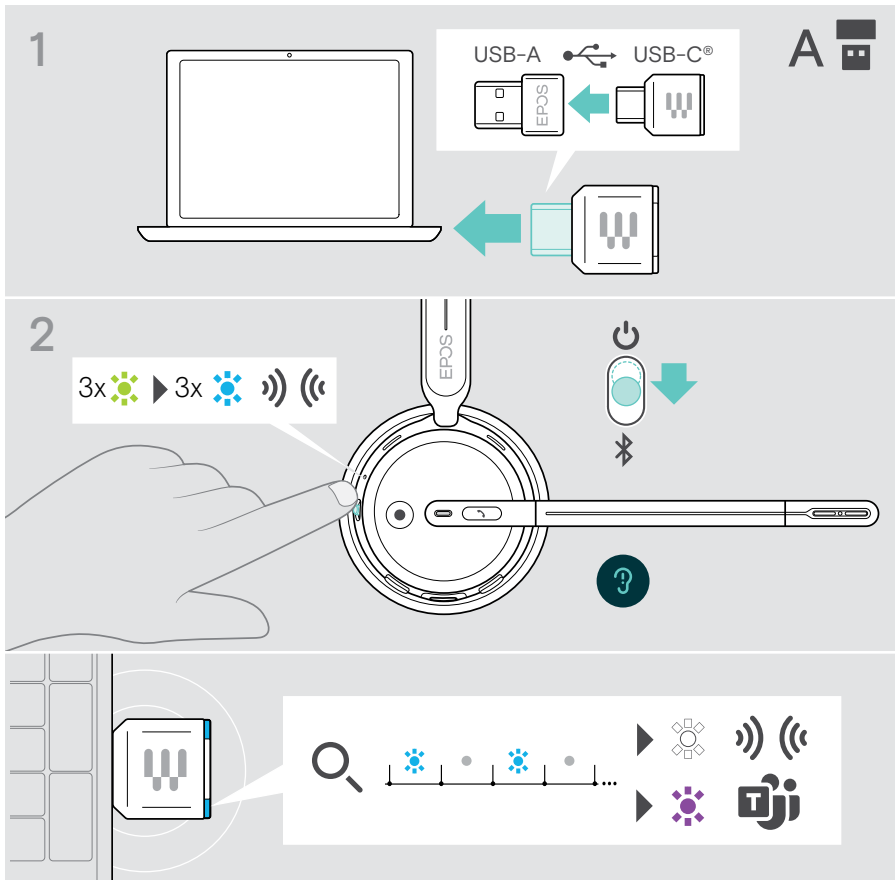

B Pairing with your Bluetooth® devices

To transmit data via Bluetooth, you first have to pair your headset to a wireless device. The delivered dongle is already paired with the headset.

The headset can save up to eight paired devices. If you pair the headset with a ninth device, the device with the oldest activity in the pairing list will be overwritten. If you want to re-establish a connection with this device, you have to pair it again.

The headset can be connected to two of the paired devices at the same time. You can only connect another device by disconnecting one of the already connected devices.

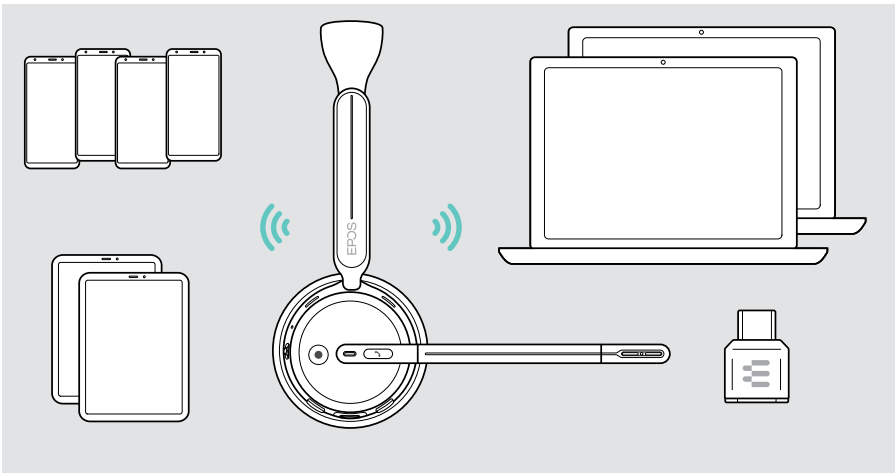

The headset complies with the Bluetooth 5.3 standard.

Bluetooth devices need to support the “Hands-Free Profile” (HFP), the “Headset Profile” (HSP), “Audio Video Remote Control Profile” (AVRCP) or the “Advanced Audio Distribution Profile” (A2DP).

Pairing the headset via Bluetooth with a mobile device

- 1 Move the Power slider to the center to switch the headset on. The LED flashes 3 times green.
Move the Power slider in the direction of the Bluetooth icon and hold it until the LED alternately flashes blue and red (pairing mode).
- 2 Search for Bluetooth devices and select **EPOS IMPACT 500** to establish the connection – see instruction manual of your mobile device. Once the headset is paired with the mobile device, the LED flashes blue 3 times and switches off.

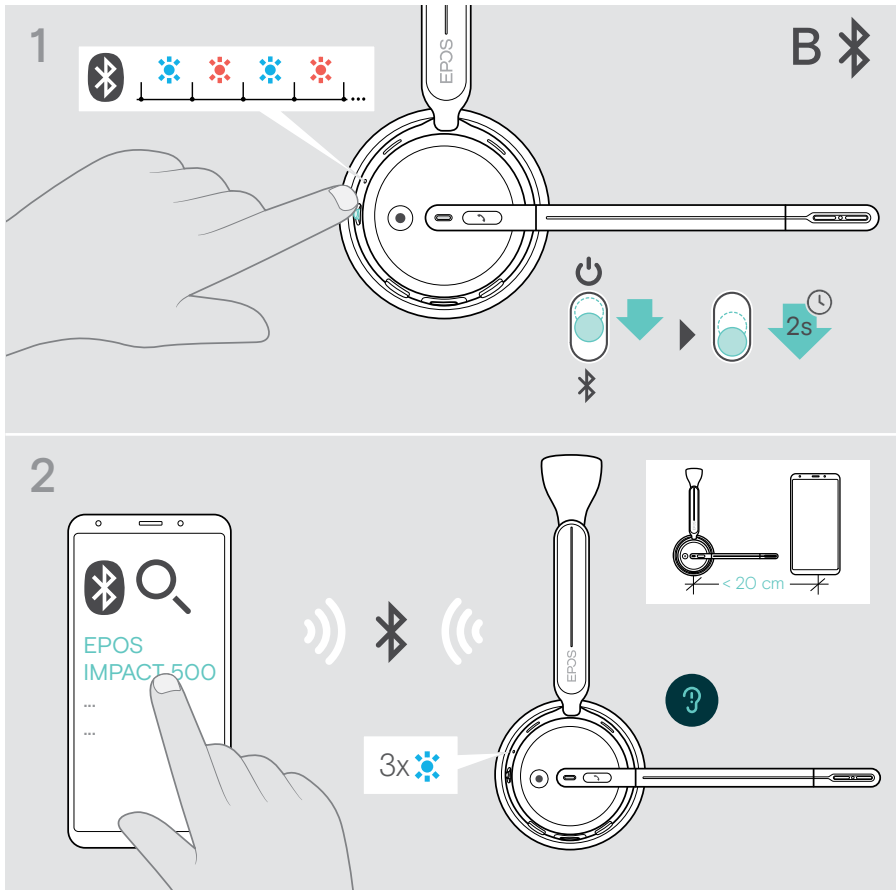

To cancel pairing:

- > Move the Power slider in the direction of the Bluetooth icon shortly.

Pairing the headset via Bluetooth with a Windows 11 PC

Some Windows 11 PCs offer a native Bluetooth connection with a good sound quality. This allows to connect the headset and the PC directly without a dongle.

To pair the headset via Microsoft Swift Pair:

- 1 Disconnect the USB cable or the dongle from your PC.
- 2 Open “Bluetooth and other device settings” in Windows and activate Bluetooth.
- 3 Activate “Device settings” > “Show notifications to connect using Swift Pair”.

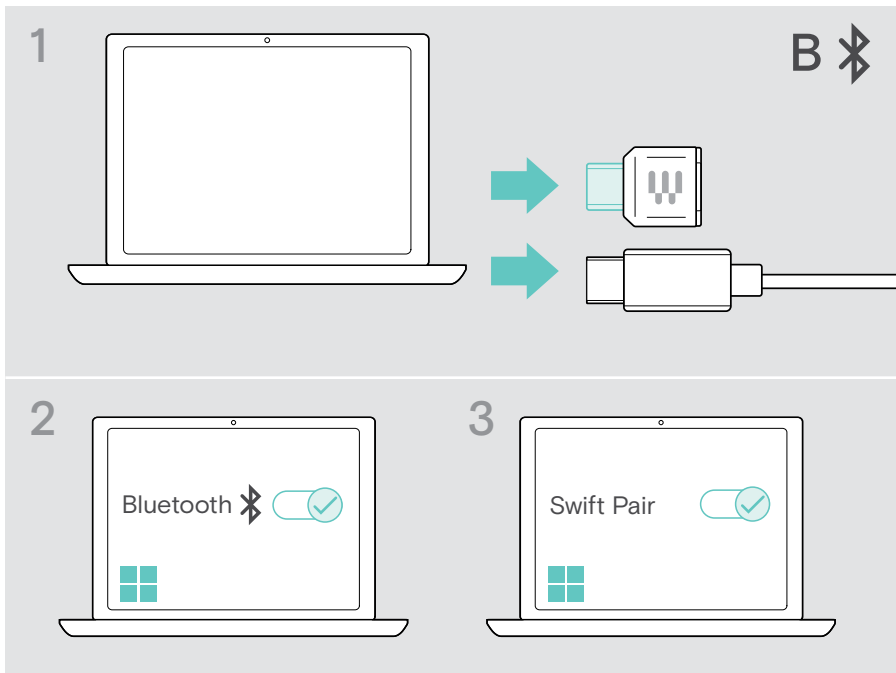

4 Put your headset into pairing mode:

Move the Power slider to the center to switch the headset on. The LED flashes 3 times green.

Move the Power slider in the direction of the Bluetooth icon and hold it until the LED alternately flashes blue and red (pairing mode).



If you do not see the Swift Pair notification on the screen when you put your headset into pairing mode: Pair it manually by adding the headset in the Bluetooth Devices settings via the “Add device” button.

5 Click on “Connect” in the popup notification in the lower right corner of your screen.

The voice prompt “Pairing successful” is announced in the headset.

The LED flashes blue 3 times and switches off. The notification “Your device is ready to go” appears.

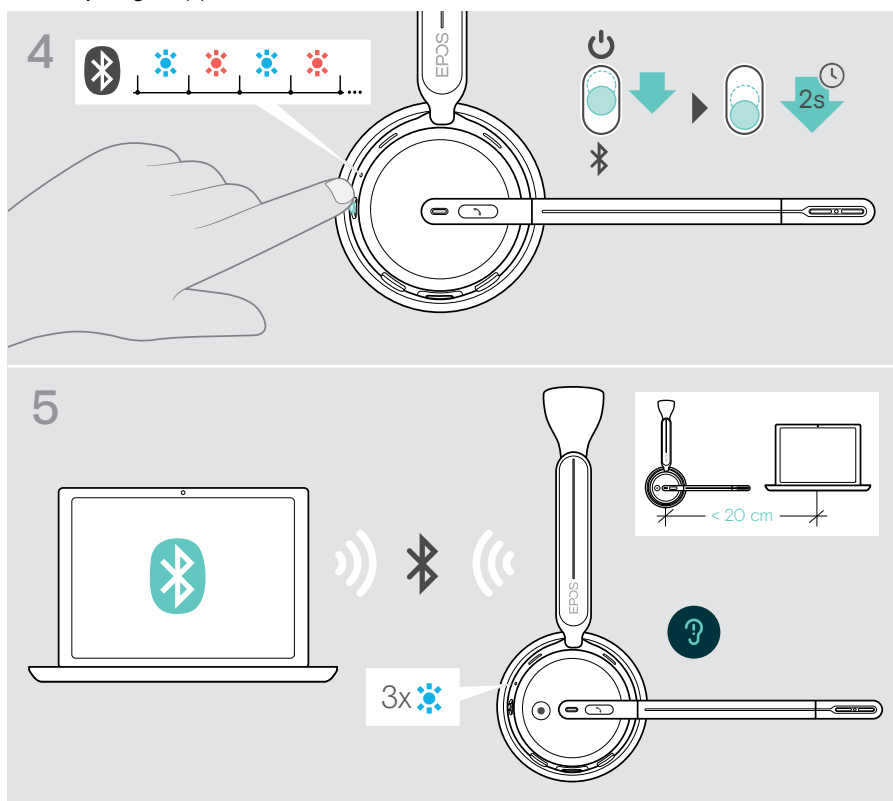

To cancel pairing:

- > Move the Power slider in the direction of the Bluetooth icon shortly.

C Connecting via USB & charge the battery

The USB cable allows to charge the headset battery while using it for calls or media reproduction.

- > Connect the supplied USB cable to the USB socket of the headset and a USB socket of your computer.

The battery is being charged. The LED pulses red, yellow, or green – depending on the battery status. When fully charged, the LED lights up green for 10 seconds and then switches off.

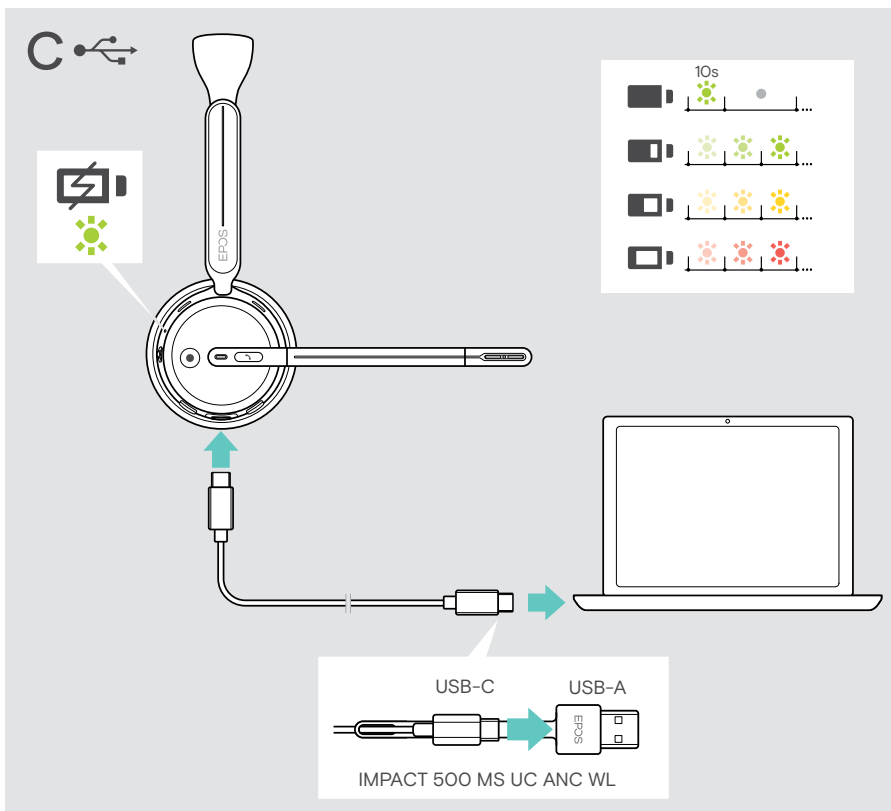

To disconnect the USB cable:

- > Pull the plugs out of the headset and your computer.

Installing the EPOS Connect mobile app

The free **EPOS Connect mobile app** allows you to configure your headset and offers additional settings.

- > Open the App Store or Google Play app on your mobile device.
- > Search for “**EPOS Connect**”.
- > Download and install the app.



Installing the EPOS Connect desktop app

The free **EPOS Connect software** allows you to configure and update your headset and offers additional settings.

- > Download the software from eposaudio.com/connect.
- > Install the software. You need administrator rights on your computer – if necessary, contact your IT department.

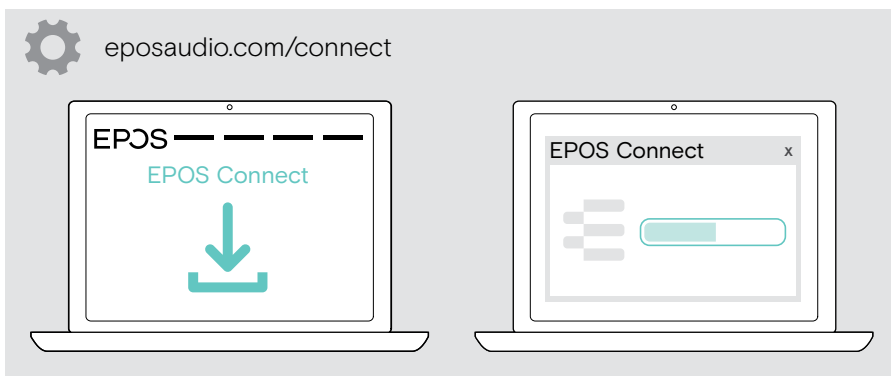

Changing audio settings – Microsoft® Windows

Windows usually changes the Audio settings automatically if you connect a new headset. If the headset is connected but you hear no sound:

- > Right-click the Audio icon.
- > Select under output BTD 900c as speaker.
- > Select under input BTD 900c as microphone.

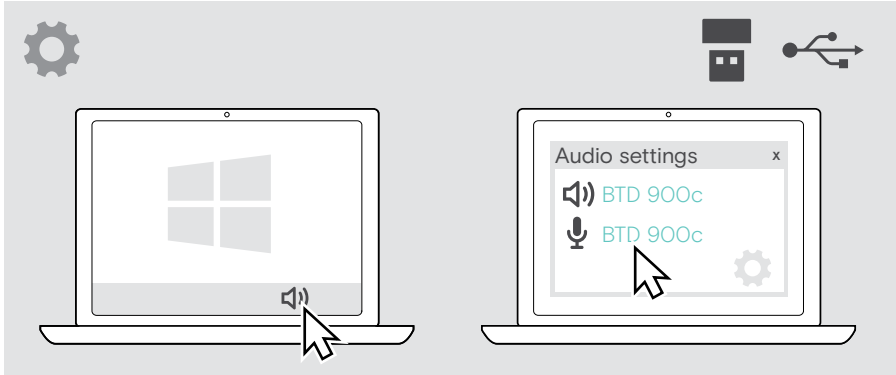

How to wear the headset

Adjusting and wearing the headset

For good sound quality and best possible wearing comfort:

- > Rotate the microphone boom to change wearing side.
- > Adjust the headset so that the ear pads rest comfortably on your ears.
- > Change the wearing side in [EPOS Connect](#) to swap the stereo channels.

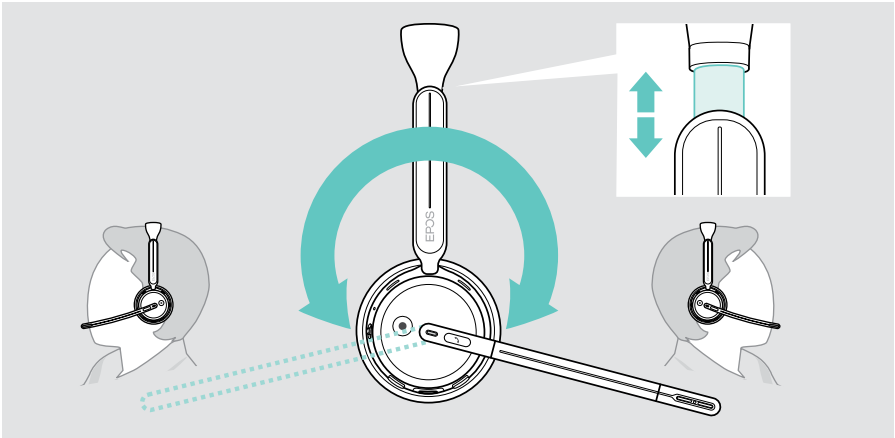

Positioning the microphone

- > Bend and rotate the boom arm so that the microphone is about 0.8" (2 cm) from the corner of your mouth.

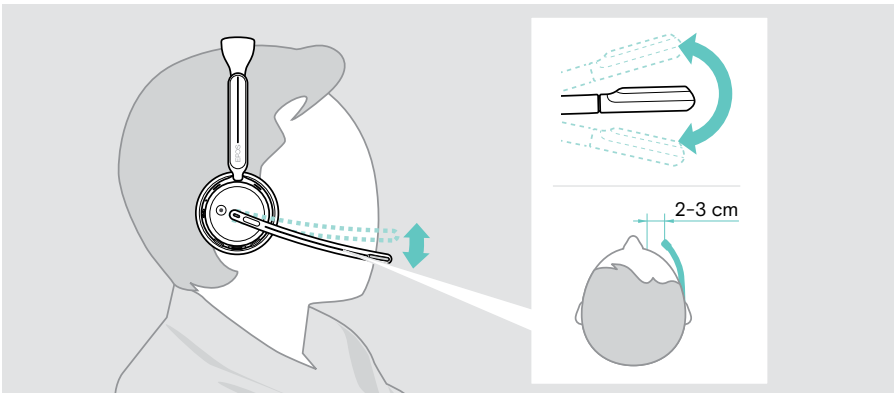

How to use – the basics



CAUTION

Risk of hearing damage!

Listening at high volume levels for long periods can lead to permanent hearing defects.

- > Set the volume on your connected device to a low level before putting on the headset.
- > Do not continuously expose yourself to high volumes.

Switching the headset on – auto connect

- > Move the Power slider to the center to switch the headset on. The LED flashes 3 times green. The headset automatically tries to connect to the 2 latest used devices. If these are not available, the headset tries to find other paired devices. Once the connection is successfully established, you hear a voice prompt and the LED flashes 3 times blue.

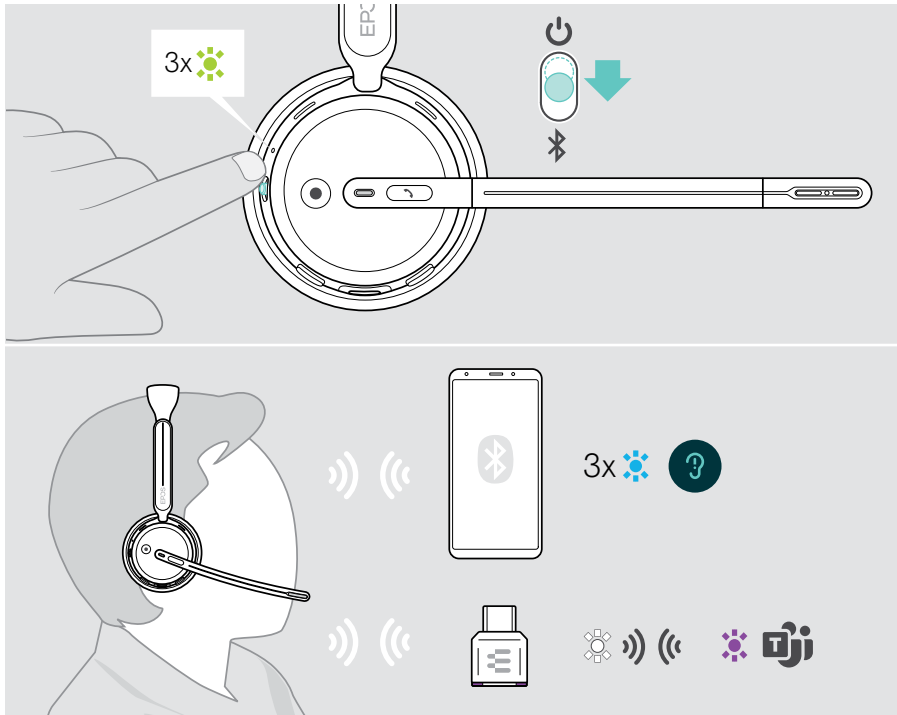

Switching the headset off

- > Move the Power slider in the direction of the standby icon. The LED flashes red 3 times and the headset switches off.

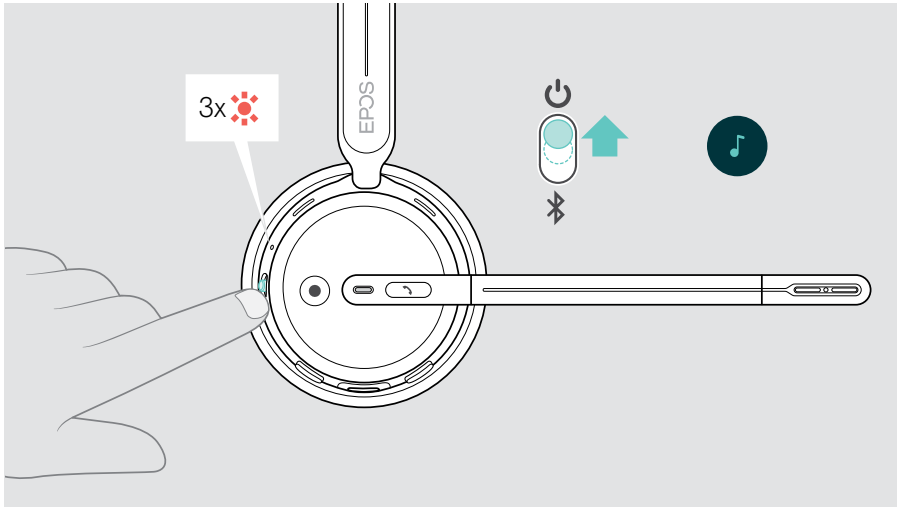



- > Charge the headset – see page 39.





The headset switches off after 6 hours to save battery power if there is no audio signal. Switch the headset off and on again to use it. You can set or deactivate the time for auto power off in EPOS Connect.

Changing the volume

You can adjust two independent volume settings for the headset:

1   **Call and media volume**
during an active call or media streaming

2   **Ring tone, tones and voice prompts volume**
when headset is in idle mode
(not during a call or media streaming)

- > Tap the volume button + or - to increase or reduce the volume. **OR**
- > Press and hold the button for fast volume changes.

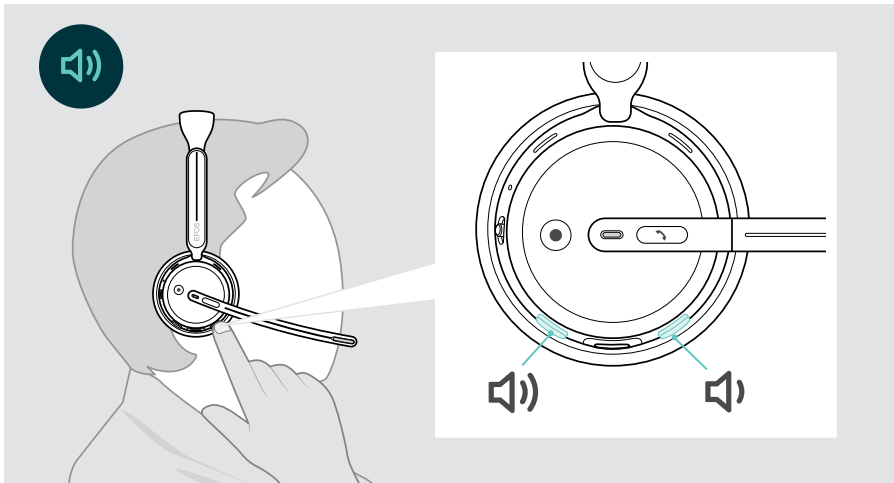

 Alternatively, you can adjust the volume for calls and media streaming on your connected device.

Adjusting the headset's microphone volume for softphones

- > Initiate a call on your connected device to someone who will help you find the correct volume setting for your microphone.
- > Change the microphone volume in your softphone application and/or in your computer's audio application.

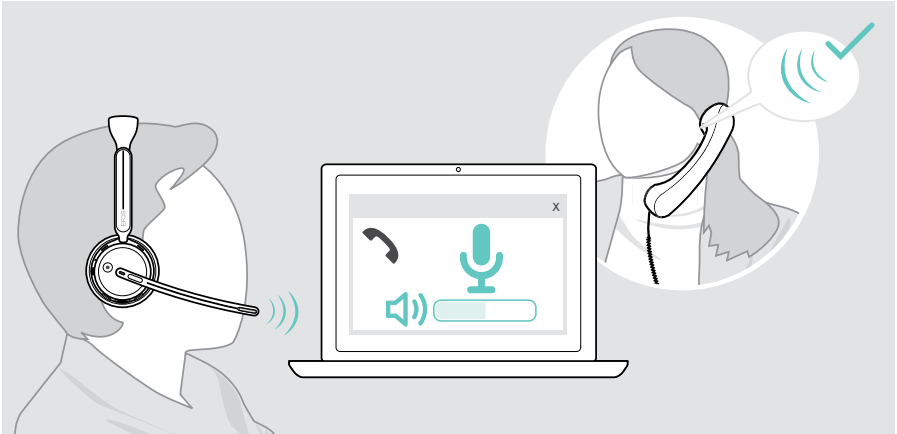

Muting the headset's microphone

- > Move the boom arm up to mute (you feel a slight resistance)* or down to unmute the microphone.
The Mute LED lights up red while muted.

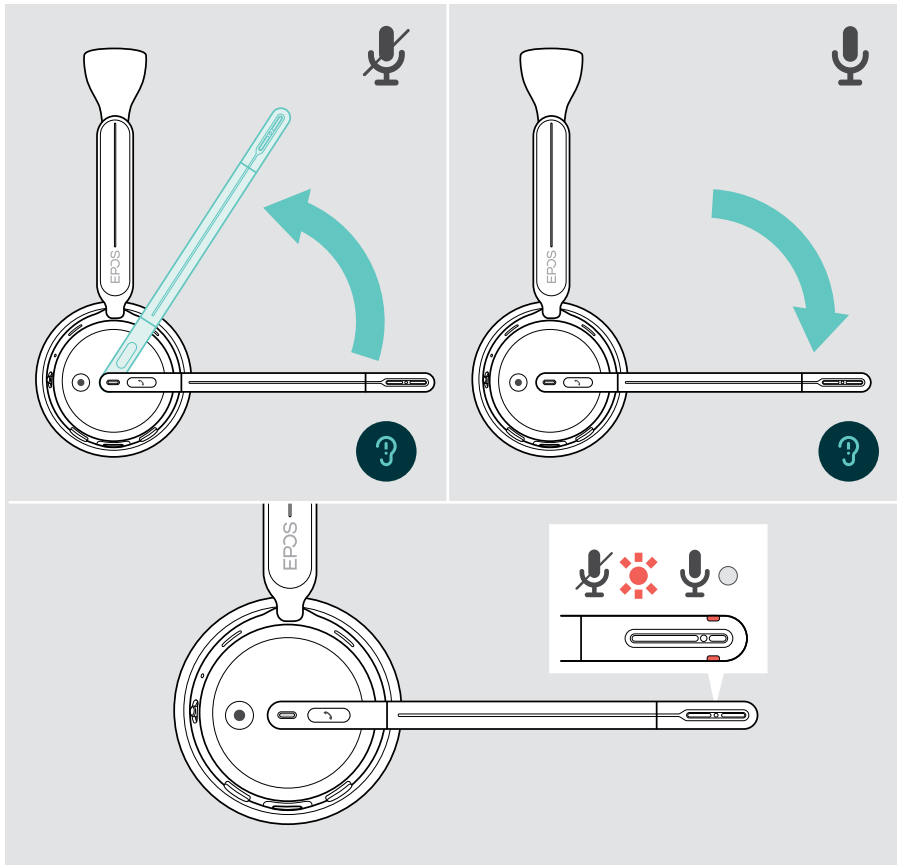

 The LED flashes red if you are talking while the microphone is muted.



*This function can be activated/deactivated via EPOS Connect.

Using Active Noise Cancellation

The IMPACT 500 provides attenuation of ambient noise using Active Noise Cancellation (ANC) technology. Special microphones reduce background noise, such as keyboard sounds or chats from colleagues in an open office environment.

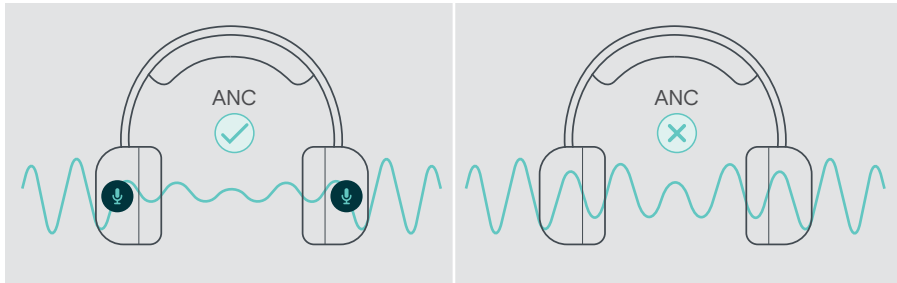

If you are in a noisy environment but would like to have your own quiet space, you can use the headset itself, disconnected from any device, and simply benefit from ANC.

Switching ANC on / off

- > Press the ANC button for 2 seconds or use EPOS Connect to activate or deactivate ANC.



You can activate ANC if the battery is sufficiently charged and if the headset is switched on.

Using TalkThrough

TalkThrough allows you to communicate with your colleagues without having to remove the headset when ANC is switched on. Media playback will be paused or muted.



Switching TalkThrough on / off

- > Activate ANC (see former pages).
- > Tap the ANC button or use EPOS Connect to activate or deactivate TalkThrough.

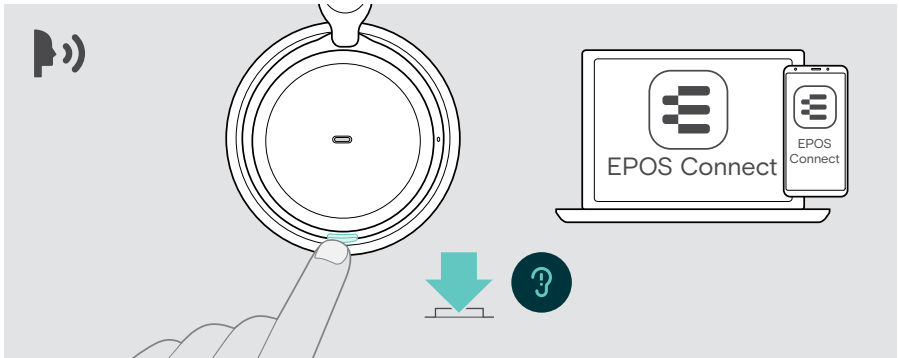

Making calls using the headset

The following functions depend on the connected device.

To make calls via the computer:

- > Install a softphone (VoIP Software) or ask your admin for support.

The Busylight LED lights up red as long as you are in a call or there is a call on hold.

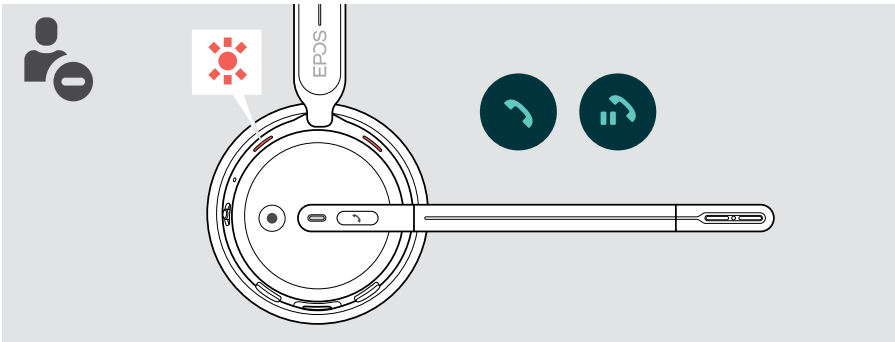

Making a call

- > Initiate the call on your connected device.

The Busylight LED lights up red as long as you are in a call.

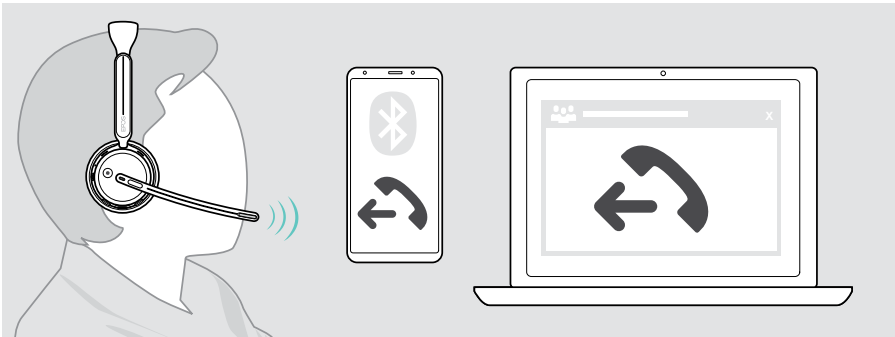

If your call is not automatically transferred to the headset:

- > Search this function in the instruction manual of your connected device.

Accepting a call

You can accept a call in two different ways:

- > **A** Tap the Hook button. **OR**
- > **B** Move the boom arm down.*

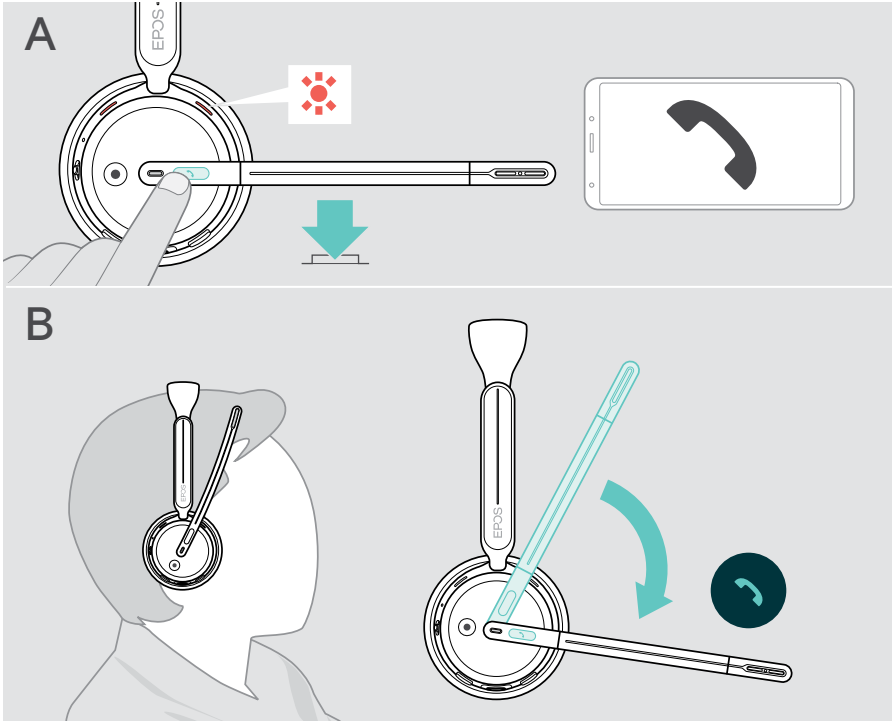

* B: This function could be activated/deactivated via EPOS Connect.

Rejecting a call

- > Press the Hook button for 2 seconds.

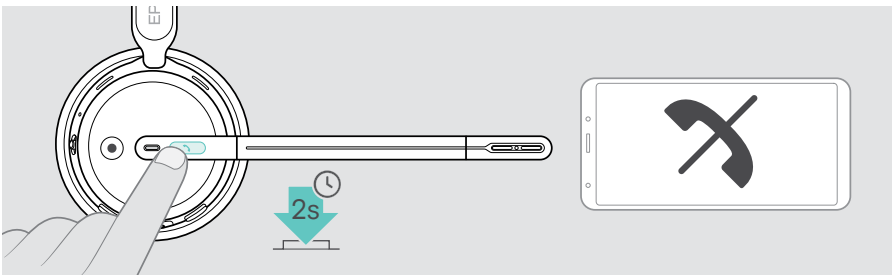

Putting a call on hold (pause)

- > Double tap the Hook button to put a call on hold or unhold the call.

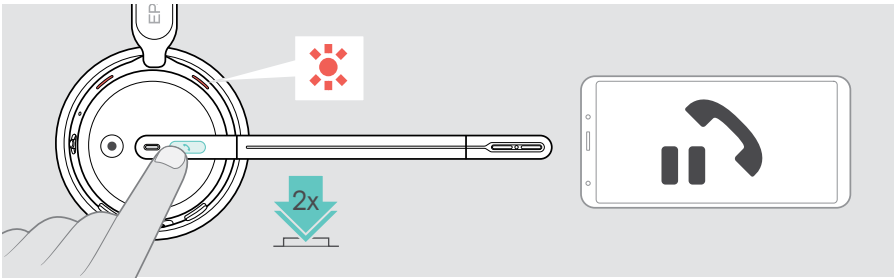

Ending a call

- > Tap the Hook button.

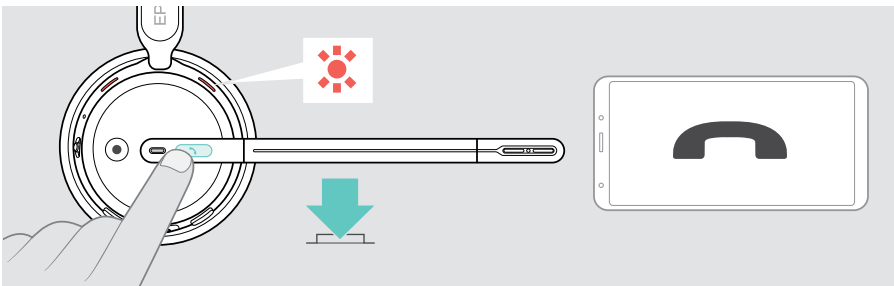

Managing multiple calls

You can use the headset with up to two connected Bluetooth devices. Two calls can be managed simultaneously. If you receive a call during an active call, a knock-on tone will be played.









Accept / reject second call

Active call	2nd incoming call	Action
		Accepts the incoming call and ends the active call
		Accepts the incoming call and puts the active call on hold
		Rejects the incoming call and continues the active call

Toggle between calls / end active call







Active call **2nd held call**

			Toggles between the active and held call
			Ends the active call and keeps the 2nd call on hold

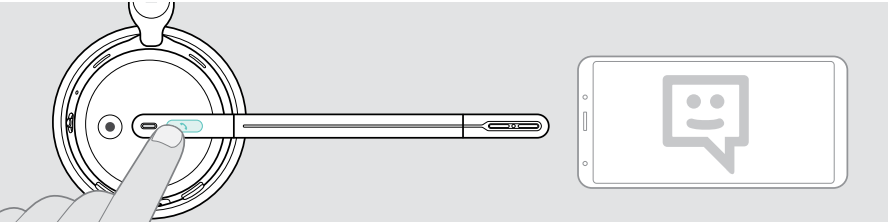
Using the voice assistant / voice dial

The last connected Bluetooth device will be used for voice assistant or voice dial.



		Activates voice assistant / voice dial
		Cancels voice assistant / voice dial

Using Microsoft® Teams

As soon as the headset recognizes Microsoft Teams on your computer (Teams handshake), the Teams function is activated on the headset.

To use Microsoft Teams with the headset:

- > **A** Make sure the headset is directly connected to your Windows 11 PC via Bluetooth – see page 17. **OR**
- > **B** Plug the dongle into the USB port of your computer – see page 14.
If Microsoft Teams is already running on your computer, the dongle LED lights up purple. Otherwise install and run Microsoft Teams.

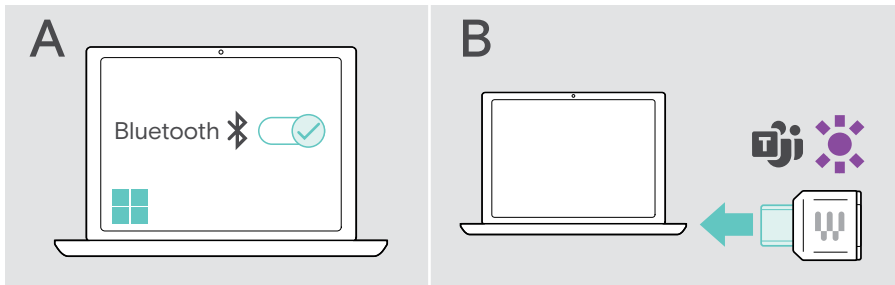

Invoking Microsoft® Teams

- > Tap the Teams button. **OR**
- > Open Microsoft Teams on your connected device.

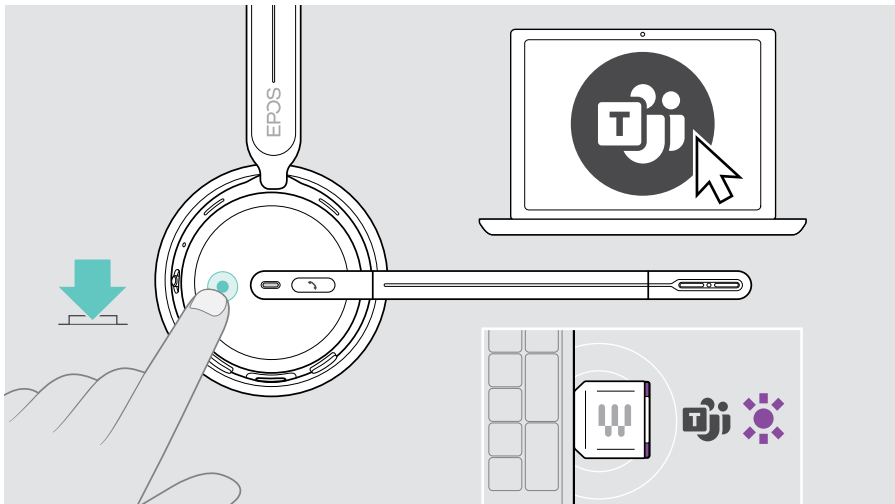

Checking Teams Notifications

The dongle LED pulses purple to indicate / Microsoft Teams shows:

- Meeting Join Notification
- Voice Mail Notification
- Missed Call Notification

To check these Notifications on your screen:

- > Tap the Teams button.



Raising hand in a Teams meeting

- > Press the Teams button for 1 second and release it to raise or lower hand.

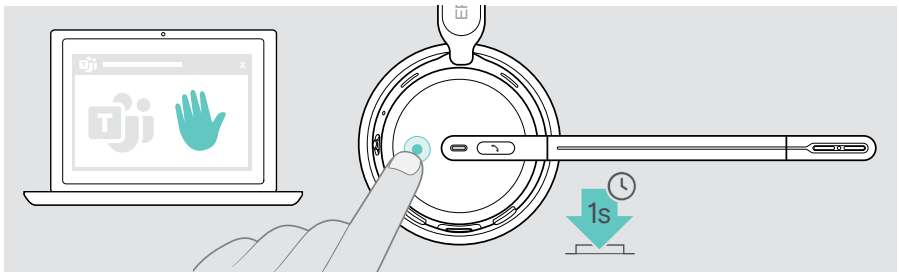

Listening to media

> Play the media on your connected device. The dongle's LED lights up white.



The following features are dependent on the support of your media player.

i If you receive and accept a call, media reproduction is paused and resumed after the call.

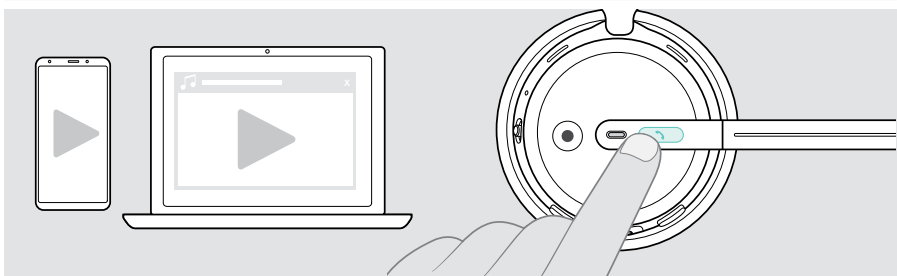

		Plays audio			Pauses audio
---	---	-------------	---	---	--------------

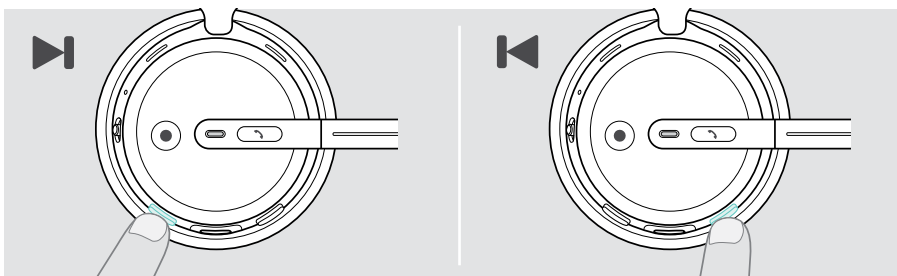

		Plays the next track			Plays the previous track
---	---	----------------------	---	---	--------------------------

i If you are connected to 2 devices: You can enable or disable the notifications from the other devices via EPOS Connect.

Good to know

Charging the headset



If the battery level of the headset gets low, the voice prompt “Recharge Headset” is announced.

When the battery is empty, the headset switches off automatically.
 > Connect the USB cable to use the headset while charging.

**Charging time
via USB cable**

**Talk time
ANC off**

**Talk time
ANC on**

10 minutes



5 hours

4 hours
45 minutes

1 hour
30 minutes



35 hours

32 hours

If you do not use the headset for extended periods of time:

- > Charge the built-in rechargeable battery every 3 months for about 1 hour.

Charging via USB cable

The USB cable allows to charge the headset battery while using it for calls or media reproduction.

- > Connect the USB cable to your headset and your computer (see page 19).
The battery is being charged. The LED pulses red, yellow, or green – depending on the battery status. When fully charged, the LED lights up green for 10 seconds and then switches off.

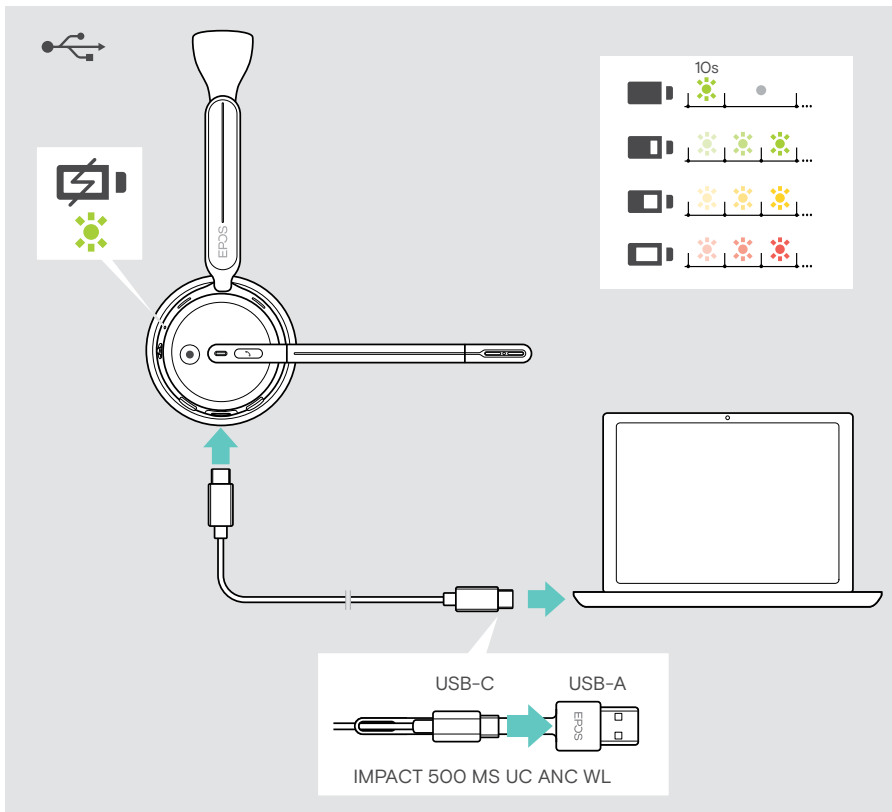

Verifying battery power / remaining talk time

You can check the battery status of the headset in EPOS Connect. Some mobile devices also indicate it.

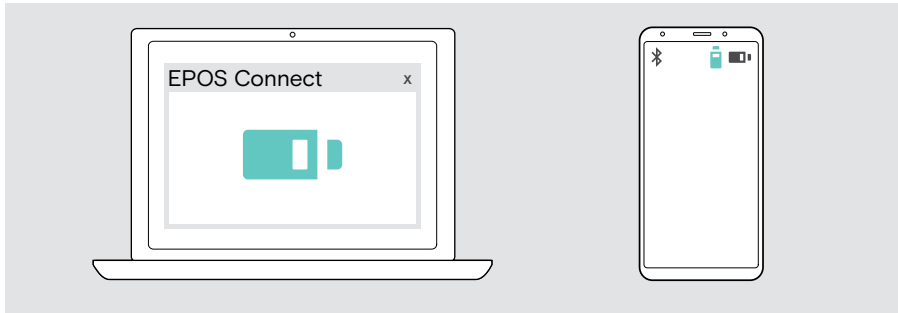

You can verify the remaining talk time at any time except when you are in a call/ listening to media:

- > Move the Power & Bluetooth slider shortly in the direction of the Bluetooth icon.

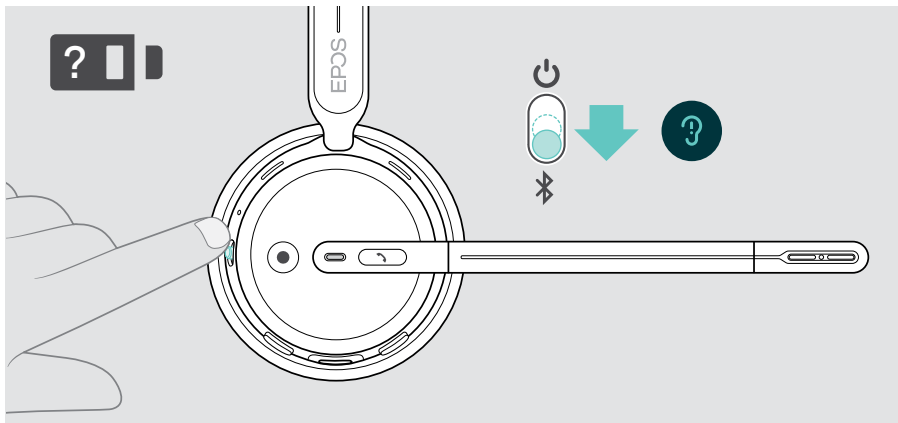

LED	Information announced
 3x 	"Battery High"
 3x 	"Battery Medium"
 3x 	"Battery Low"

Adjusting the Sidetone

Sidetone is the audible feedback of your own voice during a phone call.

- > Change the strength for the Sidetone in [EPOS Connect](#).

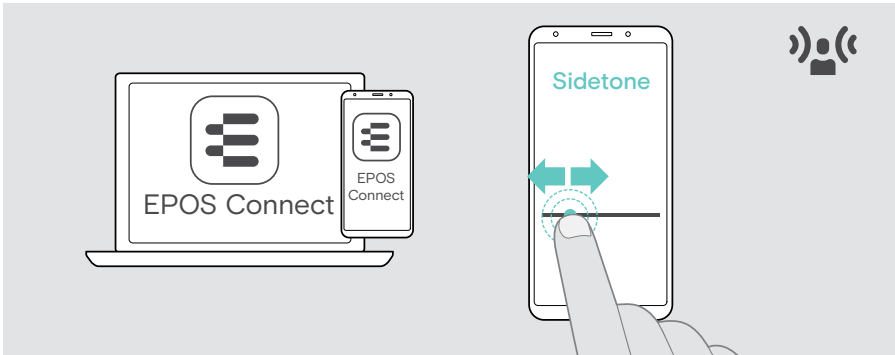

Changing the voice prompts' language

- > Choose the corresponding voice prompts' language from the list in [EPOS Connect](#) (English by default).

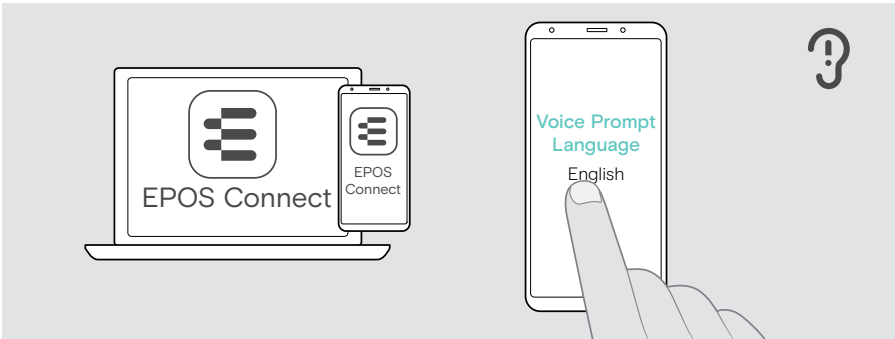

Enabling / disabling voice prompts and tones

> Activate or deactivate the voice prompts and tones in **EPOS Connect**.

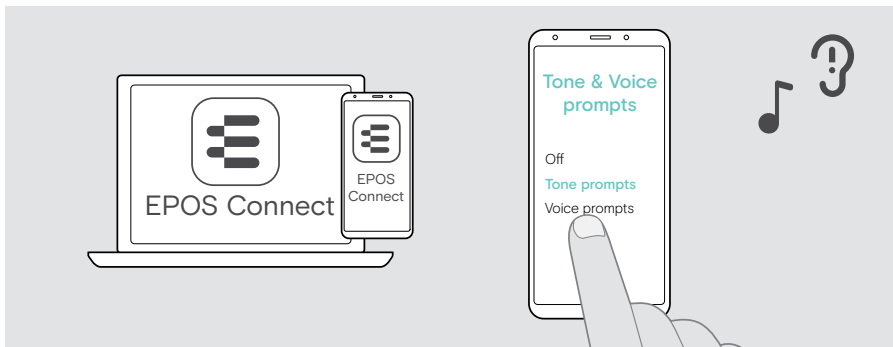

Off	Deactivates tones and voice prompts; few exceptions e. g. rechargeable battery is empty
Tone prompts	Deactivates voice prompts; headset plays tones only
Voice prompts	Activates tones and voice prompts
No prompts during calls	Deactivates all prompts during calls; except Teams Raise Hand and low battery warning

Changing settings for media mode

> Choose whether starting a 2nd media reproduction should keep the 1st audio or swap to the 2nd in **EPOS Connect**. **Calls are not affected.**

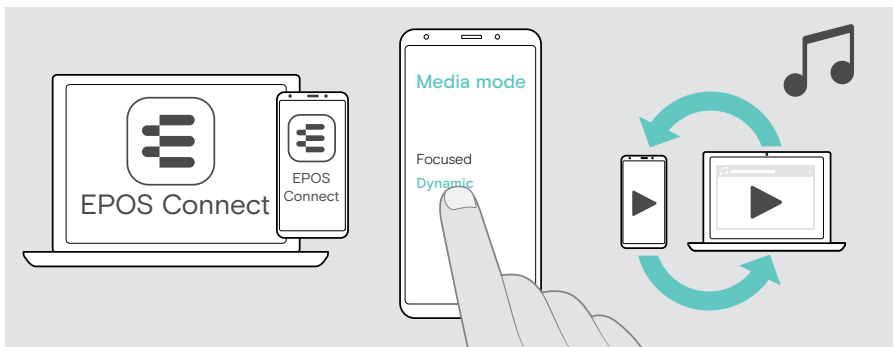

Focused	Keeps current audio; ignores the 2 nd media reproduction
Dynamic	Switches to the newly started audio

Enabling / disabling an Audio Limiter

> Choose an Audio Limiter in [EPOS Connect](#).

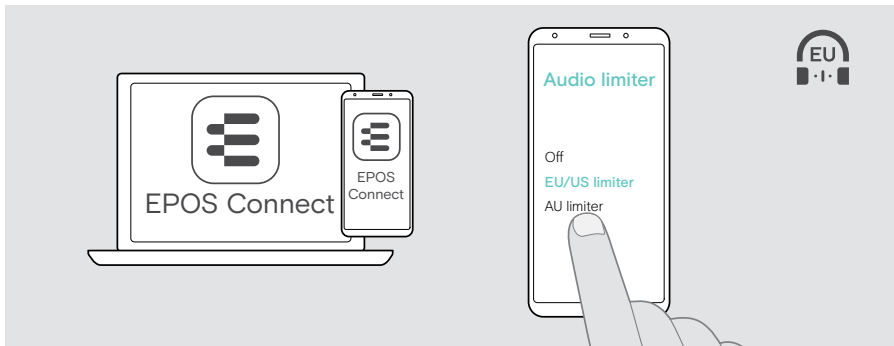

Off	Deactivates limiter
EU/US limiter	Activates limiter: max. 90 dB; compliant with Directive 2003/10/EC
AU limiter	Activates limiter: max. 85 dB; compliant with Directive AS/ACIF G616:2006

Enabling / disabling Busylight LED

> Change the settings in [EPOS Connect](#).

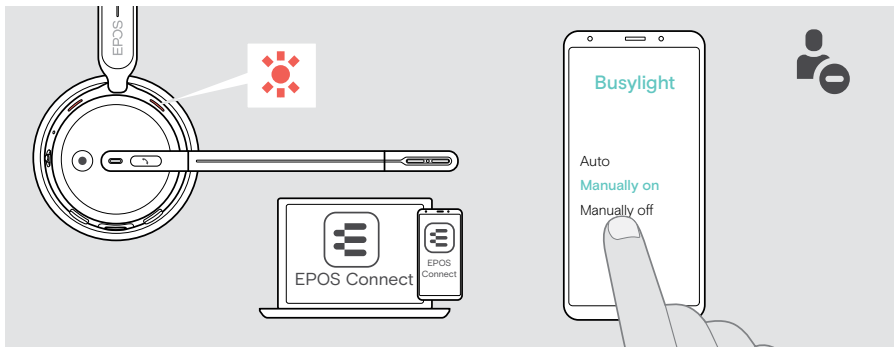

Auto	Activates busy light automatically when in a call
Manually on	Switches the Busylight LED on; indicates that you are busy, even if you are not in a call
Manually off	Switches the Busylight LED off

Enabling / disabling mute notifications

> Change the settings in **EPOS Connect**.

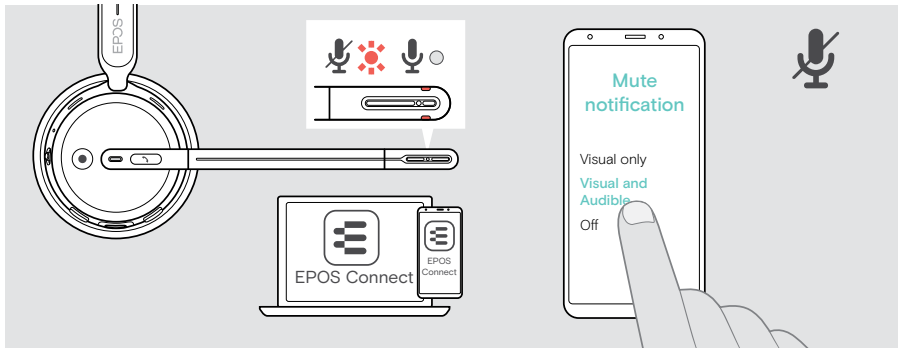

Visual only	Shows mute notification via LEDs only
Visual and Audible	Activates mute notification via LEDs and voice prompt / tone
Off	Deactivates LEDs and voice prompt / tone
Mute notification interval	Sets interval for headset muted reminder to 1 minute, 5 or 10 minutes

If you are close to leave the Bluetooth range

The range between headset and Bluetooth device is device dependent. The transmission range largely depends on environmental conditions such as wall thickness, wall composition etc.

With a free line of sight, the transmission range of most Bluetooth devices is up to 30 meters.

If you are close to leave the transmission range of the connected Bluetooth device, you hear a tone in the headset. The audio quality deteriorates e. g. during a call. If you leave the transmission range the link breaks down completely.

- > Re-enter the radio range of the Bluetooth device.
The connection is re-established automatically.

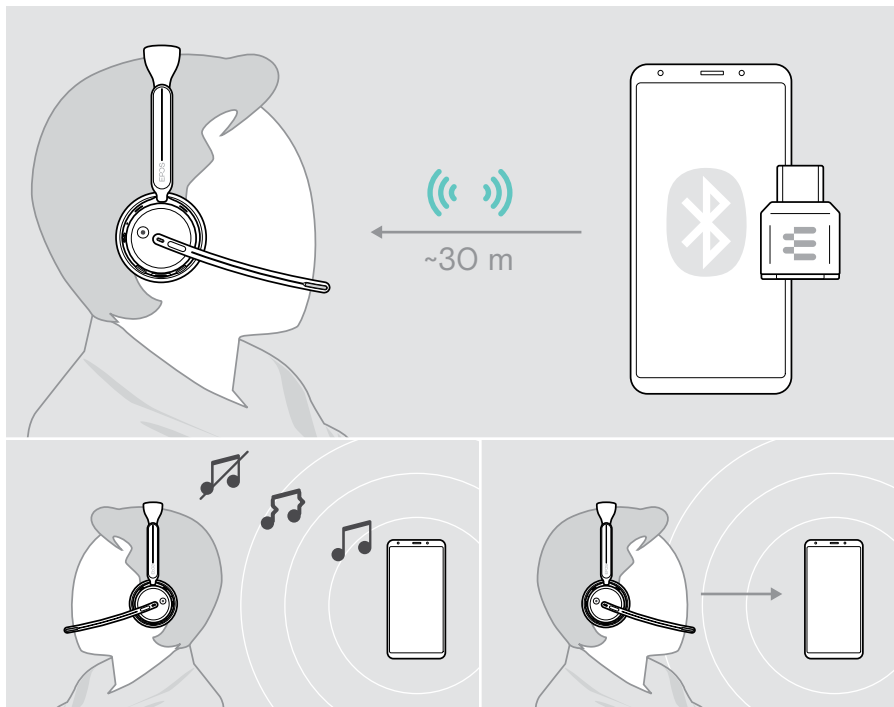

Pairing with the dongle

In case you purchased a new BTD 900c dongle as an accessory or reset your paired device list:

- 1 Plug the dongle in.
- 2 Move the Power slider in the direction of the Bluetooth icon and hold it until the LED alternately flashes blue and red (pairing mode).
- 3 Use a pointed object (e.g. a ball pen) to press and hold the dongle's pairing button for 2 seconds. The LED alternately flashes blue and red too. Once the dongle and the headset are connected, both LEDs flash 3 times blue. The dongle LED lights up constantly.

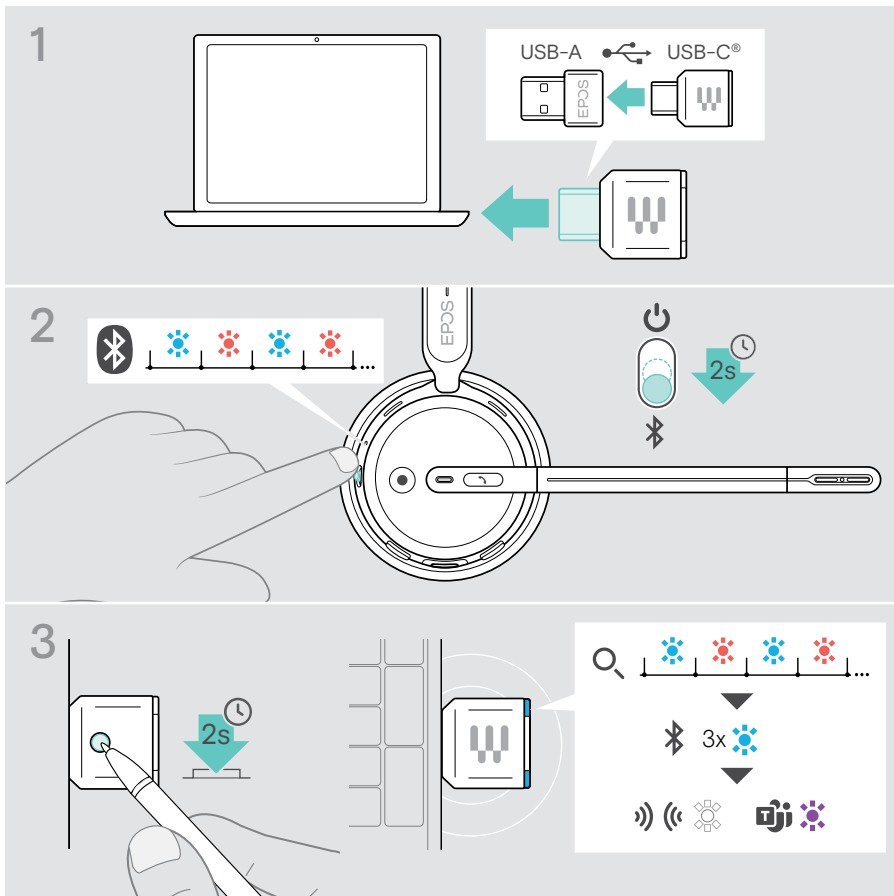

It may take a few moments for the devices to find each other and connect.

Maintaining & updating products

Cleaning the products

WARNING

Liquids can damage the electronics of the product!

Liquids entering the housing of the device can cause a short circuit and damage the electronics.

- > Keep all liquids away from the product.
 - > Do not use any cleansing agents or solvents.
- > Use a dry cloth to clean the product only.

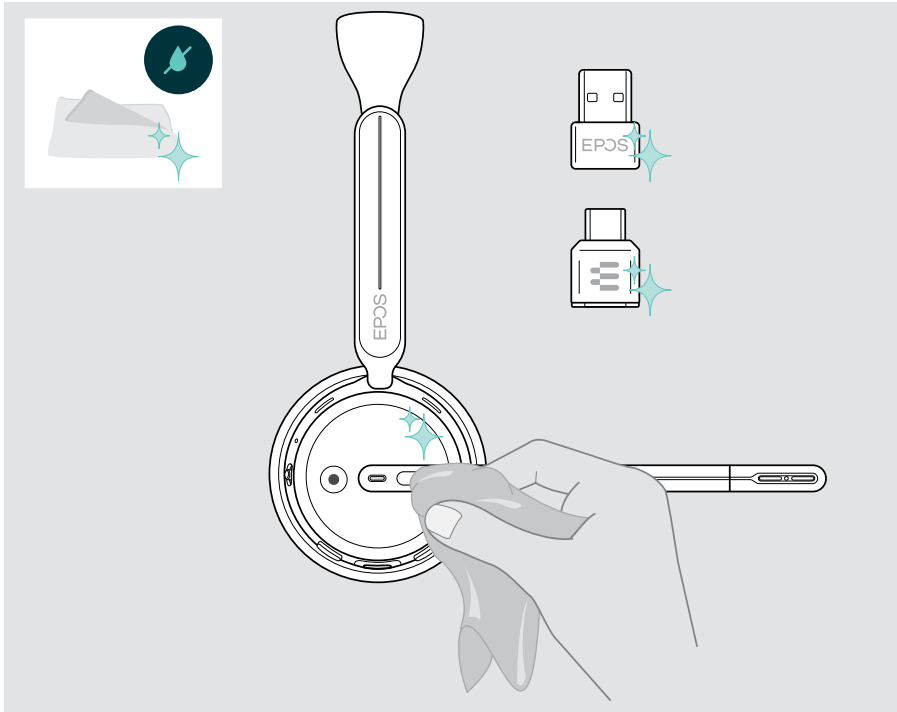

Transporting and storing the products

- > Keep the products in a clean and dry environment.

To avoid nicks or scratches on the headset and the dongle:

- > Store the headset and the dongle in the pouch when not in use or when carrying it around. Lift the boom arm and twist in the ear cup(s).

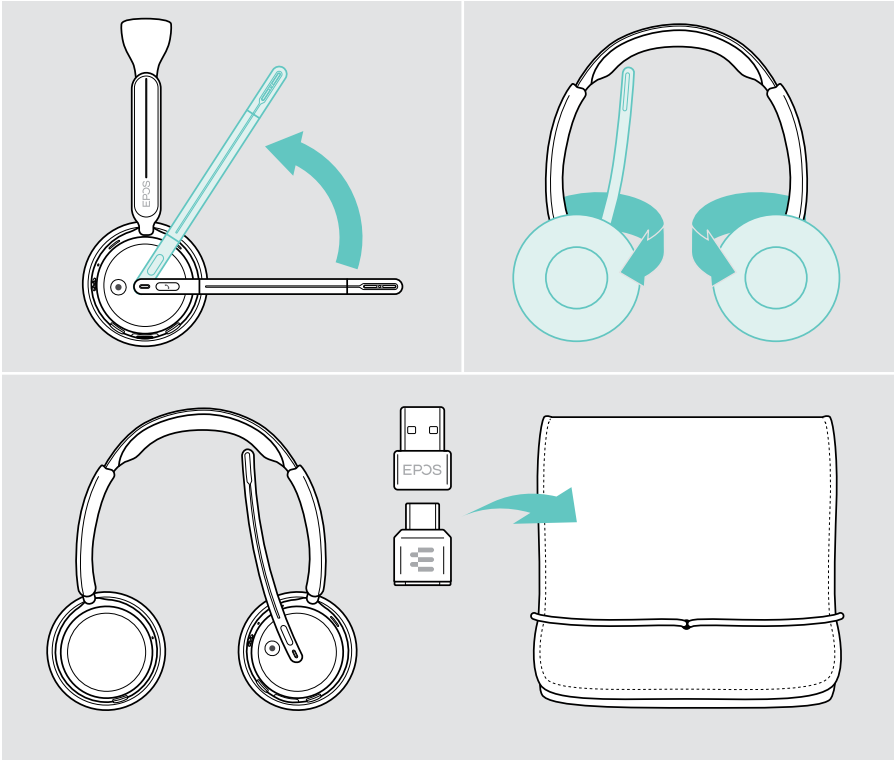

If you do not use the headset for extended periods of time:

- > Charge the rechargeable battery every 3 months for about 1 hour.

Replacing the ear pad(s)

For hygienic reasons, replace the ear pad(s). Spare ear pads are available from your EPOS partner.

- 1 Lift the boom arm and twist in the ear cup(s).
- 2 Grasp the edge of the ear pad behind the ear cup and peel it up and away from the ear cup.
- 3 Slide the edge of the new ear pad into the small recess. Carefully rotate the ear pad anti-clockwise until it is fully attached.

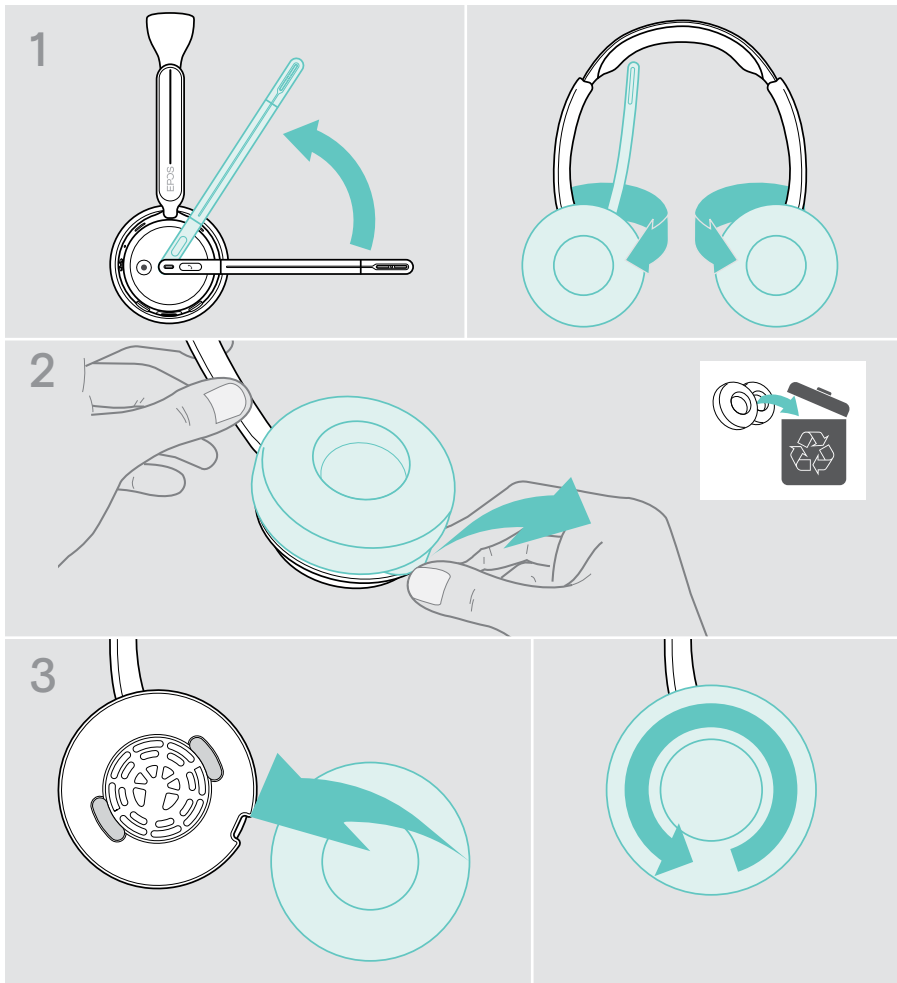

Updating the firmware

You can update the firmware of your headset and dongle by using the free **EPOS Connect** software (see page 20).

Updating the firmware via EPOS Connect desktop app

- > Connect the USB cable to your headset and your computer.
Move the Power slider to the center to switch the headset on.
OR
- > Plug the dongle into the USB port of your computer. The LED flashes blue.
- > Start **EPOS Connect**.
If there is a new firmware available the software will guide you through the update process.

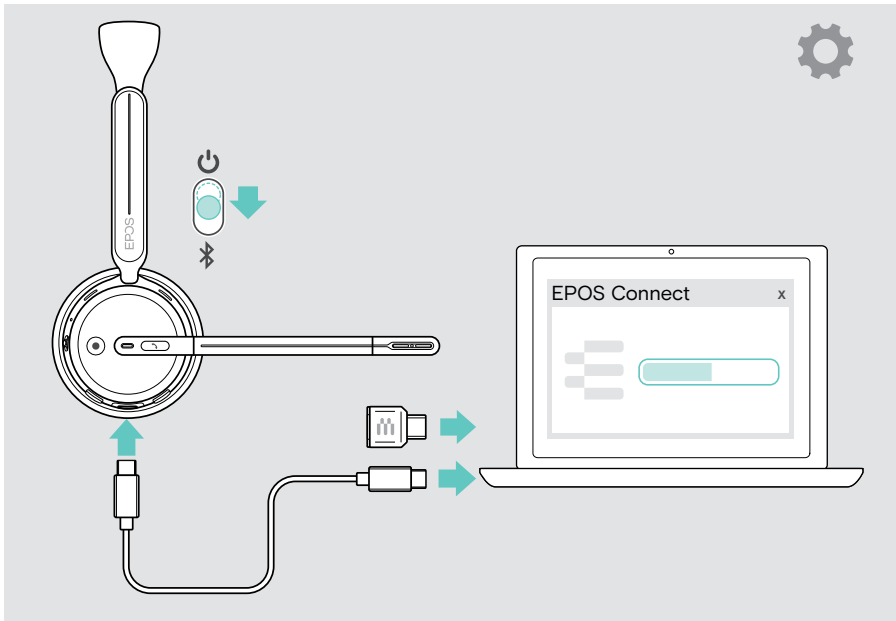

Updating the firmware via EPOS Connect mobile app

- > Move the Power slider to the center to switch the headset on.
- > Start the **EPOS Connect mobile app** on your connected mobile device. If there is a new firmware available, the software will guide you through the update process.

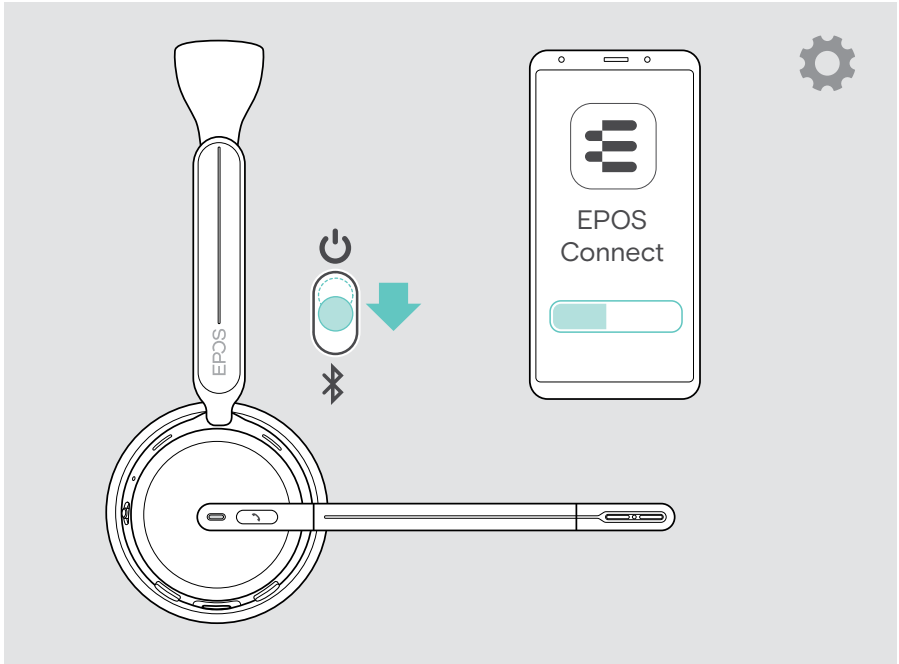

Updating the firmware via EPOS Connect Web app

- > Connect the USB cable to your headset and your computer.
Move the Power slider to the center to switch the headset on.
OR
- > Plug the dongle into the USB port of your computer. The LED flashes blue.
- > Open your web browser and go to eposconnect.enterprise.eposaudio.com to open up the **EPOS Connect Web app**.
Follow the instructions of the **EPOS Connect Web app**. If there is a new firmware available, it will be shown in the “Updates” section.

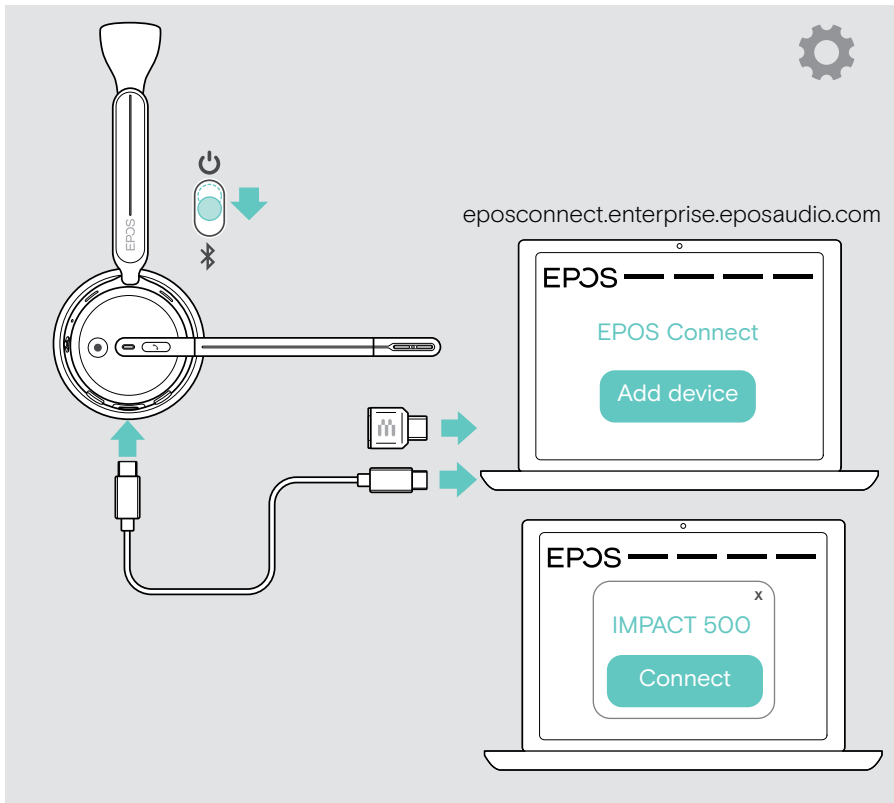

Replacing the headset's rechargeable battery

- > Go to eposaudio.com/support/battery-replacement-guide.
- > Follow the instructions given in the **Battery removal and replacement guideline** for the IMPACT 500 Series.



eposaudio.com/support/battery-replacement-guide

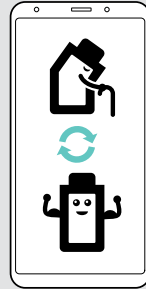
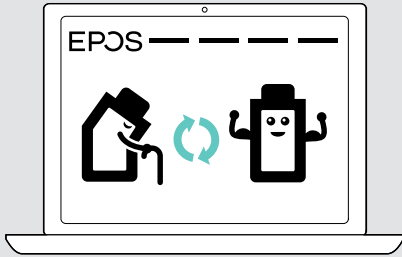

If a problem occurs...



Many functions can be activated/deactivated or adjusted via the software:

- > Check the settings in [EPOS Connect](#).

Problem	Possible cause	Solution	Page
Headset cannot be switched on	Rechargeable battery empty	> Recharge the headset battery. Use the headset with the USB cable during charging.	39
Headset switched off but button in on position	Battery saving mode: headset switches off after 2 or 6 hours (no audio signal + setting via EPOS Connect)	> Switch the headset off and on again.	23 39
Active Noise Cancellation (ANC) cannot be switched on	Rechargeable battery empty	> Recharge the headset battery. Use the headset with the USB cable during charging.	39
	Headset switched off	> Switch the headset on.	23
No audio signal or drop outs	Headset not paired with a Bluetooth device or dongle	> Pair the headset.	15
	Volume adjusted too low	> Increase the volume on the headset during a call or media streaming or on your connected device.	25
	Headset or connected device switched off	> Switch the headset or device on.	23
	USB cable's plugs not fully inserted	> Insert the plugs again.	19
Headset cannot be connected via Bluetooth	Headset not paired	> Pair the headset.	15
	Bluetooth at connected device deactivated	> Activate Bluetooth.	-
	Dongle not plugged in	> Connect the dongle to your computer.	14
Beeps instead of voice prompts	Voice prompts disabled	> Enable voice prompts via EPOS Connect.	43
Voice prompts too loud or quiet	Volume for voice prompts adjusted too high or low	> Increase the volume on the headset in idle mode (no call or audio streaming).	25
Stereo sound mirrored	Headset wearing side swapped	> Change the wearing side setting via EPOS Connect.	22

Problem	Possible cause	Solution	Page
You hear your own voice too loud	Sidetone adjusted too high	> Change the sidetone setting via EPOS Connect.	42
Microsoft Teams does not work	Dongle or Microsoft Teams disturbed	> Unplug and plug in the dongle again.	-
		> Re-start Teams on your device.	-
Dongle does not work	Dongle plugged into a monitor USB port	> Connect the dongle to your computer.	14
Laptop screen switches off	Some laptops register a magnet and switch off the screen	> Do not hang your headset on top of a laptop screen as it contains a magnet in the headband.	-
Headset or dongle does not react to any button press	Software or hardware problems	> Switch the headset off and wait for 10 seconds.	39
		> Switch the headset on again.	23
		> Unplug and plug in the dongle again.	14
		> Clear the pairing list of the headset.	57
		> Clear the pairing list of the dongle.	58
		> Reset the headset to the factory default settings.	57

If a problem occurs that is not listed here or if the problem cannot be solved with the proposed solutions, please contact your local EPOS partner for assistance.

To find an EPOS partner in your country, search on eposaudio.com.

Clearing the pairing list of the headset

- > Use **EPOS Connect** to reset the headset.
OR
- > Move the Power slider to the center to switch the headset on. The LED flashes 3 times green.
- > Move the Power slider in the direction of the Bluetooth icon and hold it until the LED flashes 3 times white. The pairing list is cleared. The headset tries to pair with Bluetooth devices (see page 15).

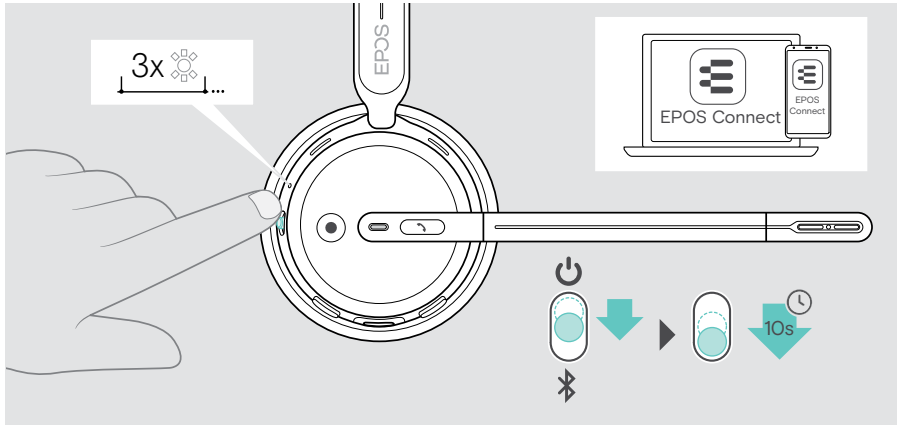

Restoring factory default settings (Reset)

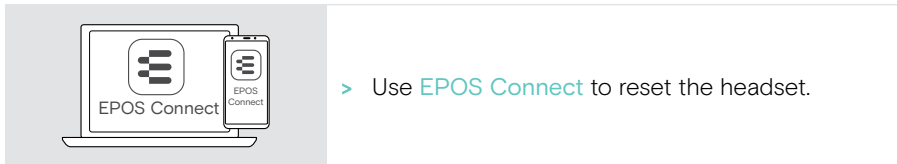

Clearing the pairing list of the dongle

- 1 Plug the dongle into the USB port of your computer.
- 2 Use a pointed object (e.g. a ball pen) to press and hold the button for 5 seconds. The LED flashes white 3 times. The pairing list is cleared. The dongle searches for Bluetooth devices to pair with – see page 47.

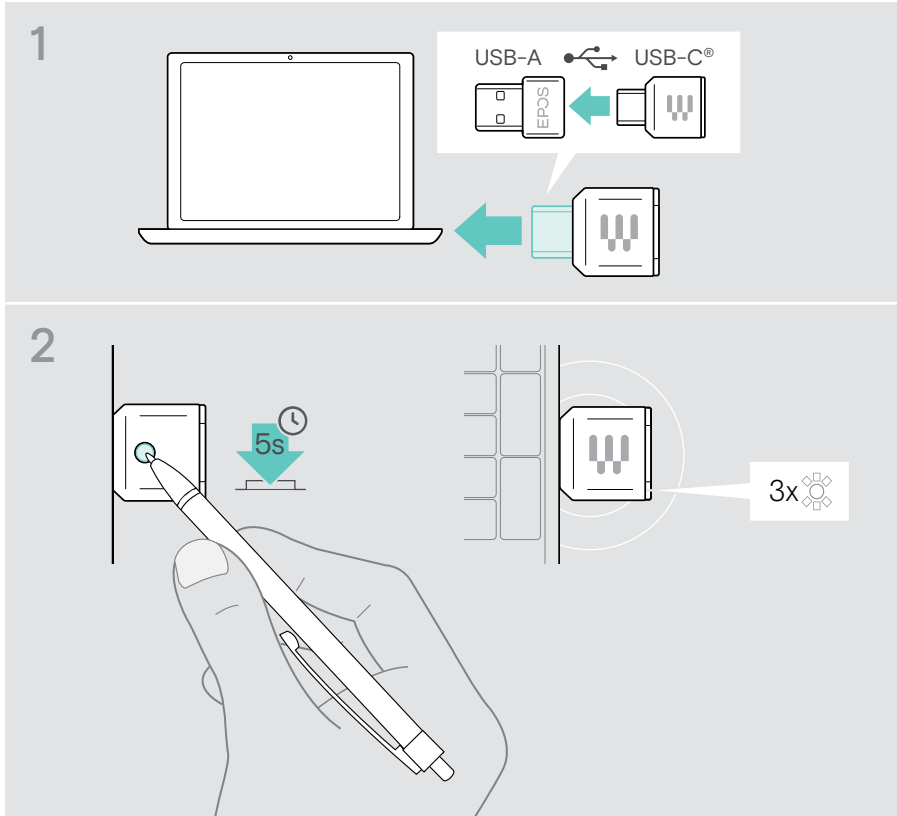

eposaudio.com/impact500

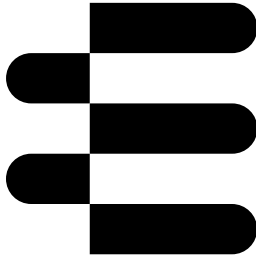

DSEA A/S

Kongebakken 9, DK-2765 Smørum, Denmark
eposaudio.com

09/25, A01